

# PAOLONESI

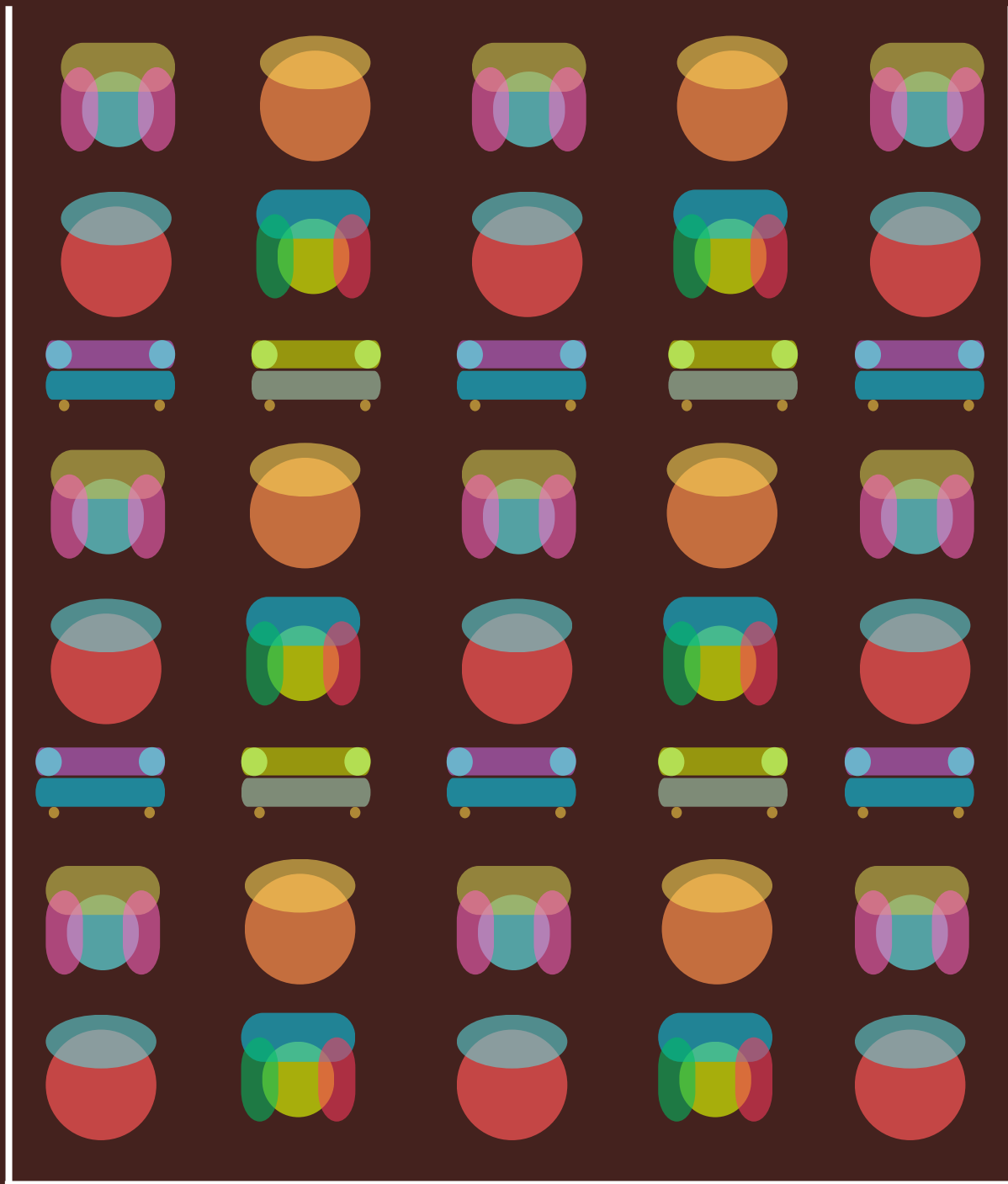



# PAOLONESI

F I R E N Z E 1 9 6 2

"We collaborate with the foremost textile companies globally, adhering to the highest standards of quality and timeliness."

---

It is the only company in central Italy that can guarantee consistent levels of production of the highest quality, since 2020 it has been the first custom upholstery in Italy certified ISO 9001, 14001 and 45001.

The internal collaborators are all Tuscan artisans with great experience, born and raised within the great Italian artisan tradition. The product is proudly 100% MADE IN ITALY. For many years investments have been made in new sales networks aimed at improving and giving potential to the products, with the great ambition of positioning itself in the furniture market as one of the most important brands at an international level. For this project the sales network has been extended with agents in Northern Europe, Southern Europe, Africa and the Middle East.

# Index / Circle-D

Snaked /11



Snaked Outdoor /21



Tiamo/ 31



Tiamo Outdoor/ 40



Graphius / 46



Graphius Outdoor / 53



Demonte-Moi/61



Grace / 71

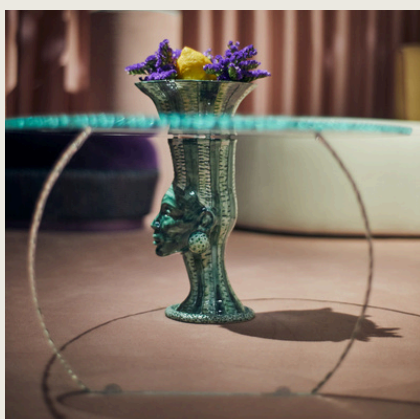

Martingale Outdoor/ 81



# Index / Craft Wave

Misstake/92



Jimmy/100



Snaked/ 108



Graphius/114



Tiamo / 122



Tiamo Outdoor/130

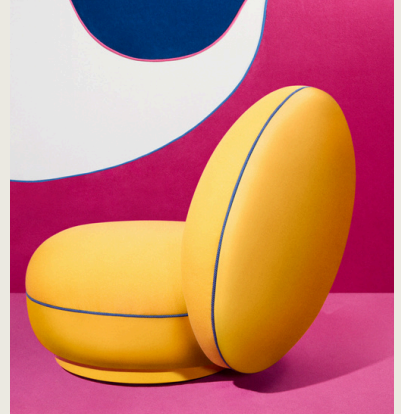

Jimmy/89



Tecnical details/ 139

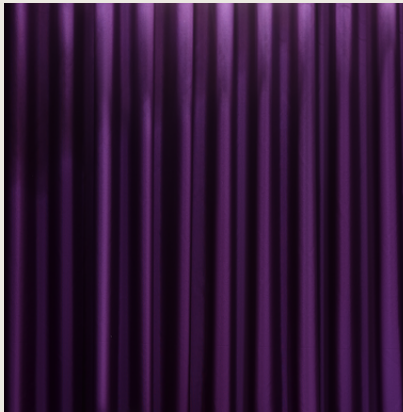

# Circle•D

---

## Collection 2025

**Circle•D** non è solo una collezione, ma un modo di vivere lo spazio. È il luogo in cui il design incontra l'anima, dove ogni pezzo si modella sulle esigenze di chi lo abita, creando ambienti che accolgono, ispirano e trasformano.

La Collezione di **Paolo Nesi** nasce per chi cerca più di un semplice arredo: per chi desidera un'esperienza, un'emozione. Le **forme fluide e modulari** si adattano ai ritmi della vita contemporanea, rendendo ogni spazio un rifugio di comfort e bellezza.

Il viaggio continua – perché il design non è mai statico.

È un processo in continua evoluzione, proprio come noi.

---

**Circle•D** is more than just a collection—it's a way of experiencing space. It is where design meets the soul, where each piece adapts to those who inhabit it, shaping environments that welcome, inspire, and transform.

**Paolo Nesi's** Collection is created for those who seek more than just furniture—it's for those who desire an experience, an emotion. **Fluid, modular forms** adapt to the rhythm of contemporary life, turning every space into a sanctuary of comfort and beauty.

The journey continues—because design is never static. It is a process in constant evolution, just like us.



# Snaked

/ Giuseppe Dicecca

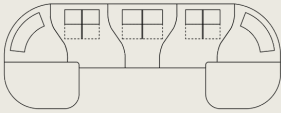

## Modular sofa

**Snaked** è un divano creato per poter far vivere i 12 differenti moduli in migliaia di combinazioni e colori.

Il processo creativo improntato sulle rotondità degli elementi è file-rouge che lega gli elementi alla loro **modularità**, concetto che permette di curare ogni specifica esigenza di spazio e forma. Il piping a contrasto ne sottolinea le **curve sinuose**, aggiungendo un tocco di vivacità e raffinatezza.

---

**Snaked** is a sofa designed to bring its 12 different modules to life through endless combinations of shapes and colors. Its creative process is rooted in the softness of curved elements, a guiding thread that connects each element to its **modularity**. This design approach allows for tailored solutions that meet specific spatial and aesthetic needs.

Contrasting piping enhances its **sinuous curves**, adding a vibrant yet refined touch.

/ Indoor

R



















# Snaked

/ Giuseppe Dicecca

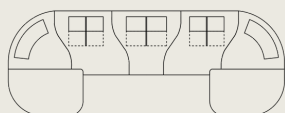

## Modular sofa

**Snaked** è il divano modulare pensato anche per ambienti esterni, con 12 moduli combinabili in infinite soluzioni.

Le curve morbide e il profilo a contrasto donano carattere e dinamismo.

Se per l'Indoor la sua gommapiuma è ecosostenibile, per l'Outdoor è il Dryfeel® che la rende unica; unità cellulare completamente aperta che consente all'acqua e all'umidità di passarvi attraverso in modo rapido ed efficace, assicurando il massimo confort in ogni condizione di umidità.

**Snaked** is the modular sofa also designed for outdoor environments, with 12 modules that can be combined in infinite solutions.

The soft curves and contrasting piping give character and dynamism.

If for Indoor use its foam rubber is eco-sustainable, for Outdoor use it is the Dryfeel® that makes it unique; a completely open cellular unit that allows water and humidity to pass through it quickly and effectively, ensuring maximum comfort in any humidity condition.



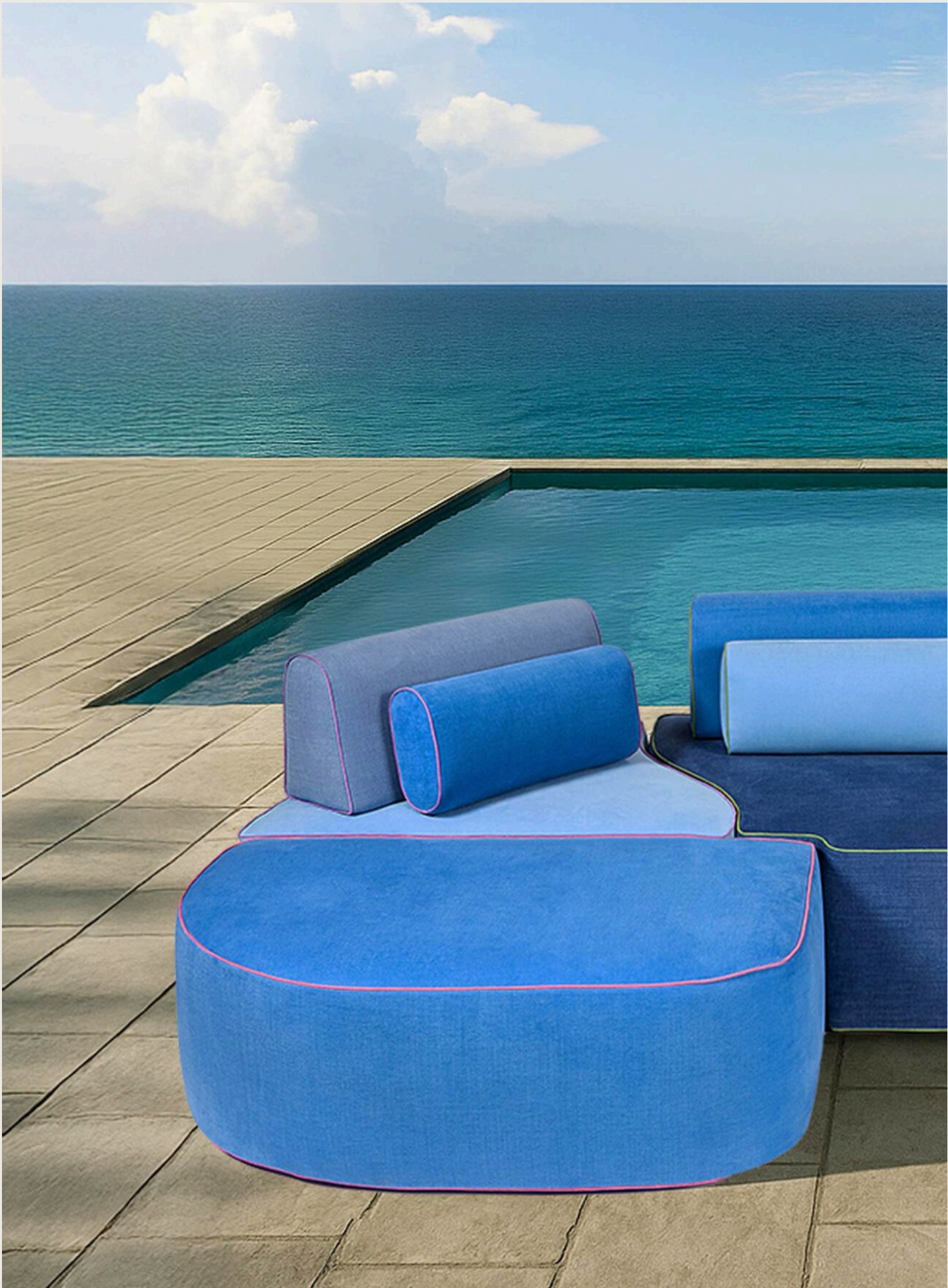















# Tiamo

/ Giuseppe Dicecca

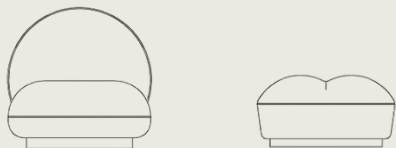

## Swivel Armchair / Lepouf

La poltrona **Tiamo** è l'incontro perfetto tra comfort e allegria, con le sue linee morbide e tondeggianti e i colori vivaci dallo spirito vintage. Un design pop e contemporaneo che porta un tocco di freschezza a ogni ambiente.

Tiamo è la scelta perfetta per chi cerca uno stile unico e pratico per il living indoor.

---

The **Tiamo** armchair is the perfect blend of comfort and fun, with its soft, rounded and vibrant lines, vintage-inspired colors. A pop and contemporary design that brings a fresh touch to any space.

Tiamo is the ideal choice for those seeking a unique and practical style for the indoor living.

/ Indoor

R















# Tiamo

/ Giuseppe Dicecca

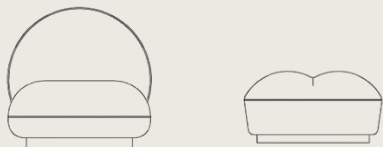

## Swivel Armchair / Lepouf

La poltrona **Tiamo** outdoor è l'incontro perfetto tra comfort e allegria, con le sue linee morbide e tondeggianti e i colori vivaci dallo spirito vintage. Un design pop e contemporaneo che porta un tocco di freschezza a ogni ambiente esterno. Il suo comfort eccezionale è garantito dall'innovativa gommapiuma **Dryfeel®**, una struttura a celle aperte che permette all'acqua e all'umidità di passare rapidamente, assicurando il massimo benessere anche nelle condizioni più umide. Tiamo è la scelta perfetta per chi cerca uno stile unico e pratico per l' outdoor.

---

The **Tiamo** outdoor armchair is the perfect blend of comfort and fun, with its soft, rounded lines and vibrant, vintage-inspired colors. A pop and contemporary design that brings a fresh touch to any outdoor space. Its exceptional comfort is ensured by the innovative **Dryfeel®** foam, an open-cell structure that allows water and moisture to pass through quickly and efficiently, providing maximum comfort in all humidity conditions. Tiamo is the ideal choice for those seeking a unique and practical style for outdoor living.

/ Outdoor











# Graphius

/ Giuseppe Dicecca



## Armchair / Modular sofa / Pouf

Eleganza modulare in forma compatta.

La poltrona **Graphius** offre versatilità, **alto artigianato fiorentino** e design sostenibile per il living indoor.

Ogni dettaglio è progettato con cura, in linea con i principi creativi della collezione, che celebrano la modularità come elemento distintivo. Grazie alla sua struttura, la poltrona si adatta facilmente a diverse configurazioni, offrendo comfort senza compromessi e una bellezza senza tempo.

Modular elegance in a compact form.

The **Graphius** armchair offers versatility, **high Florentine craftsmanship**, and sustainable design for indoor living. Every detail is carefully considered, aligning with the creative principles of the collection, which emphasize modularity as a key element.

Thanks to its smart structure, the armchair easily adapts to various configurations, offering uncompromising comfort and timeless beauty.











# Graphius globe

/ Giuseppe Dicecca

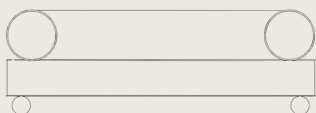

## Armchair / Modular sofa / Pouf

Il divano **Graphius Globe** interpreta i principi della collezione con linee morbide, modularità e massima adattabilità agli spazi esterni.

La base è arricchita da sfere in **acciaio** verniciato, un dettaglio distintivo e personalizzabile.

Disponibile in tre categorie tessili e un'ampia palette colori, unisce stile contemporaneo, comfort e resistenza sia indoor che outdoor.

---

**Graphius Globe** reflects the collection's core values—soft lines, modularity, and exceptional adaptability to outdoor spaces.

Its base features colored painted steel **spheres**, adding a bold and customizable accent.

Available in three fabric categories and a wide color range, it offers contemporary style, comfort, and durability both outdoor and indoor.









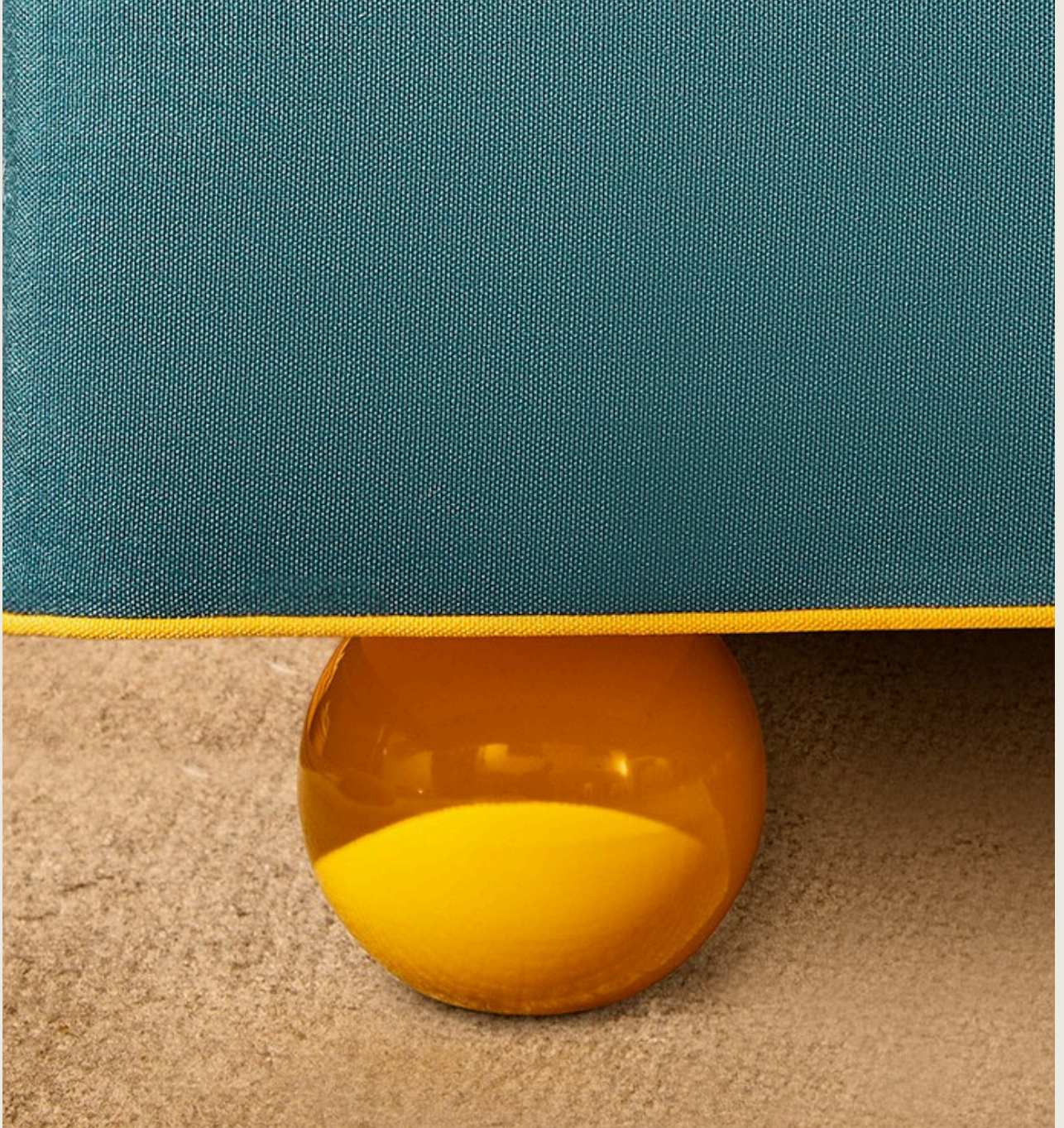





# Misstake

/ Giuseppe Dicecca



## Sofa

**Misstake** è un ironico richiamo ad un errore nato nella costruzione del classico modello Chester.

La sua struttura è stata elaborata partendo dal concetto classico donando un allure contemporaneo ed inusuale, puntando su una **sfumatura** creata dall'asimmetria.

Il gioco di colori è dato dall' inserimento di bottoni in contrasto che donano un tono pop a questa irregolare creazione.

Prodotto con la massima ecosostenibilità, Misstake è proposto in tre differenti categorie con delle cartelle colore ricche ed audaci per poter creare inusuali contrasti.



**Misstake** is an ironic reference to an error that arose in the construction of the classic Chester model. Its structure was developed starting from the classic concept, giving it a contemporary and unusual allure, focusing on a **nuance** created by asymmetry.

The play of colors is given by the insertion of contrasting buttons that give a pop tone to this irregular creation.

Produced with maximum eco-sustainability, Misstake is proposed in three different categories with rich and bold color charts to create unusual contrasts.







# Demonte-Moi

/ Giuseppe Dicecca



## Armchair

**Demonte-Moi** è la poltrona di design che gioca con i colori, un'icona di eleganza, versatilità e innovazione.

Composta da quattro elementi distinti: seduta, due braccioli e schienale, offre comfort e stile e su richiesta potrà consegnata con quattro fodere di differenti colori.

La sua struttura modulare e smontabile la rende pratica e facile da rifoderare, permettendo infinite **combinazioni cromatiche**.

Le sue forme morbide e tondeggianti evocano armonia e continuità, incarnando il concetto di circolarità come valore estetico e funzionale.

---

**Demonte-Moi** is the design armchair that plays with colors, an icon of elegance, versatility, and innovation.

Composed of four distinct elements: seat, two armrests, and backrest, it offers unparalleled comfort and style. and on request it can be delivered with four different linings.

Its modular and detachable structure makes it practical and easy to reupholster, allowing for endless **color combinations**.

Its soft, rounded shapes evoke harmony and continuity, embodying the concept of circularity as both an aesthetic and functional value.



















# Grace

/ Cori Amenta



## Coffee Table

L'arte di **Cori Amenta** incontra Paolo Nesi in una collezione esclusiva.

**Grace** sono tre coffee table unici, realizzati dai migliori maestri artigiani, trasformano la **tradizione** delle teste di moro in un racconto di **resilienza** e identità.

Ogni pezzo è un tributo alla resilienza, un'opera che racconta storie di artigianato e maestria.

Realizzati dai più raffinati maestri artigiani, sono opere d'arte senza tempo.

Il vetro, delicato e trasparente, si intreccia con dettagli in ceramica, creando un contrasto perfetto tra modernità e tradizione.

---

The art of **Cori Amenta** meets Paolo Nesi in an exclusive collection.

**Grace** are three unique coffee tables, crafted by the finest master artisans, transforming the **tradition** of the teste di moro into a story of **resilience** and identity.

Each piece is a tribute to endurance, an artwork that tells tales of craftsmanship and mastery.

Created by the most refined artisans, they are timeless works of art.

The delicate, transparent glass intertwines with ceramic details, creating a perfect contrast between modernity and tradition.



















# Martingale

/ Giuseppe Dicecca



## Armchair / Easy removable cover

**Martingale** è una poltrona outdoor e indoor che reinterpreta il modello chester in chiave contemporanea, mantenendo un perfetto equilibrio tra estetica e funzionalità. Un dettaglio chiave è la fodera over, pensata per facilitare la sua rimozione. La struttura in alluminio leggero e resistente agli agenti atmosferici è pensata per garantire durabilità e praticità anche negli ambienti esterni, mentre la **martingala** sul retro aggiunge un tocco distintivo di **raffinatezza**.

---

**Martingale** reinterprets this classic with a contemporary twist, striking a perfect balance between aesthetics and functionality. A key detail is the overlapping slipcover, designed to make removal easy and practical. The lightweight aluminum frame is built to withstand outdoor conditions, offering durability and practicality, while the **martingale** fastening at the back adds a distinctive touch of **refinement**.

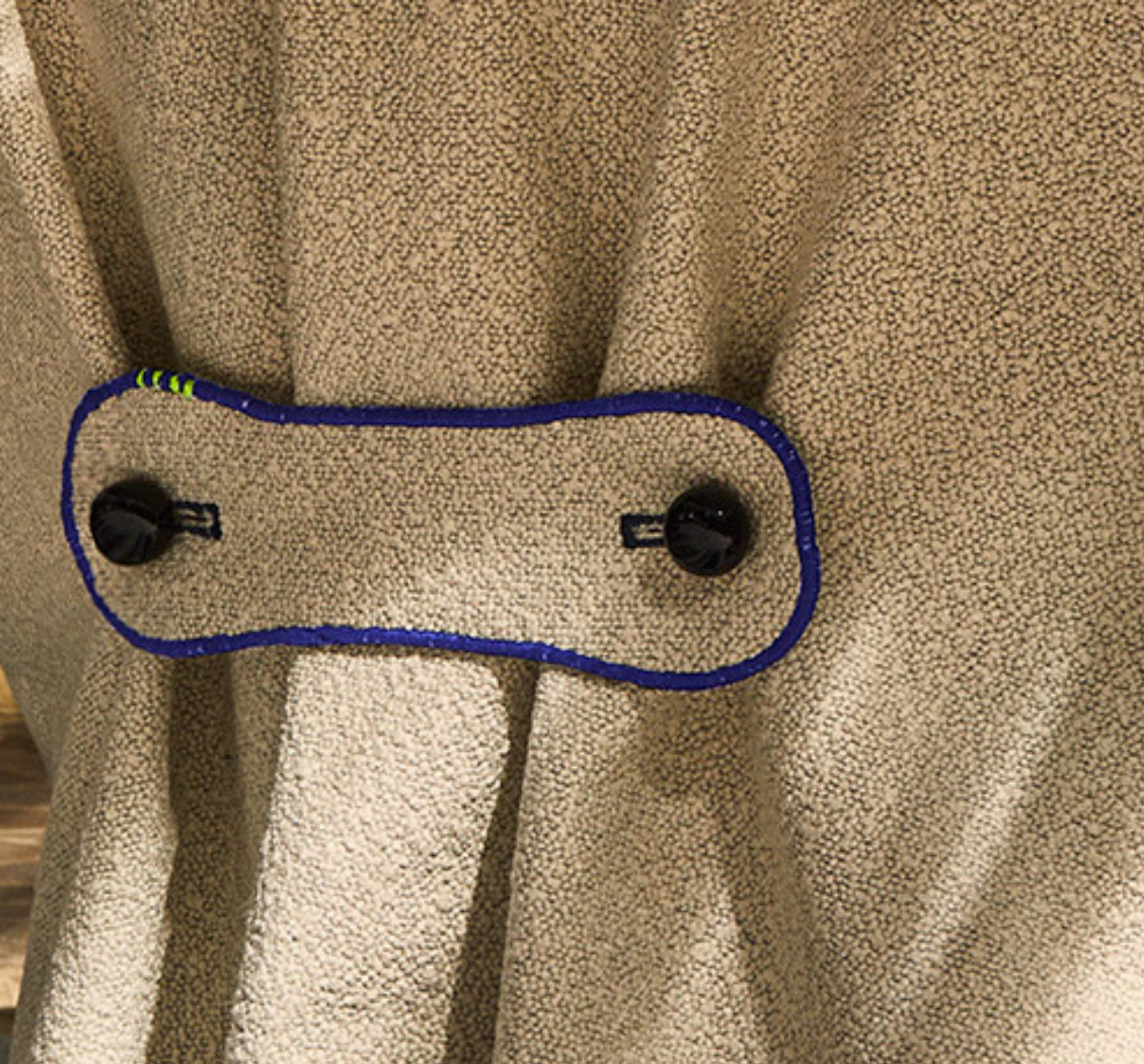









# Jimmy

/ Giuseppe Dicecca



## Stool

La chiara ispirazione anni '50 porta all' ideazione dello sgabello **Jimmy**, versatile, divertente e dall' anima vintage.

Marchio di fabbrica del Jimmy sono i suoi morbidi cilindri curvi che accolgono il “ben capitato” in una seduta sostenuta e confortevole.

---

The clear 50s inspiration leads to the creation of the Jimmy stool, versatile, fun and with a vintage soul.

The trademark of **Jimmy** are its soft curved cylinders that welcome the “welcome” in a supported and comfortable seat.







# Craft **W**aves

---

## Collection 2024

**Craft Wave** rappresenta l'emozionante presentazione della prima collezione di **Paolo Nesi**. Un viaggio nelle influenze pop, un viaggio che esplora stile e creatività attraverso affascinanti contrasti. Paolo Nesi conduce la sua visione del soft living attraverso le opere uniche del designer Giuseppe Dicecca. Insieme esploriamo le forme intriganti di poltrone e divani, scoprendo una combinazione unica di design e comfort.

---

**Craft Wave** is the exciting presentation of Paolo Nesi's first collection. A journey into pop influences, a journey that explores style and creativity through fascinating contrasts. **Paolo Nesi** leads his vision of soft living through the unique works of designer Giuseppe Dicecca. Together we explore the intriguing shapes of armchairs and sofas, discovering a unique combination of design and comfort.



# Misstake

/ Giuseppe Dicecca



## Sofa

**Misstake** è una sofisticata deviazione dal classico, un omaggio volutamente irriverente al modello Chesterfield.

La sua struttura prende origine dalla tradizione, ma se ne distacca con eleganza, grazie a un'impostazione asimmetrica che ne esalta il carattere contemporaneo e inaspettato.

L'inserimento di bottoni a contrasto introduce un gioco cromatico deciso, conferendo un **accento pop** e distintivo a una silhouette che sfida le convenzioni senza rinunciare alla raffinatezza.

Realizzata secondo criteri di massima ecosostenibilità, Misstake è proposta in tre varianti, ciascuna accompagnata da palette cromatiche ricche e audaci.

**Misstake** is a refined departure from the classic – a deliberately bold homage to the Chesterfield tradition.

Its structure originates from heritage lines, yet departs with elegance through asymmetrical volumes that reveal a distinctly contemporary and unexpected character.

Contrasting buttons introduce a confident play of color, adding a **pop-inspired accent** to a silhouette that challenges convention while maintaining an air of sophistication. Crafted with the utmost attention to eco-sustainability, Misstake is available in three curated versions, each accompanied by rich, daring color palettes.















# Jimmy

/ Giuseppe Dicecca

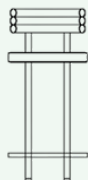

## Stool

Ispirato con eleganza agli anni '50, lo sgabello **Jimmy** unisce versatilità, carattere giocoso e un'anima dal gusto vintage.

Il suo segno distintivo sono i morbidi **cilindri** curvi che compongono la seduta: una struttura accogliente e ben proporzionata, pensata per offrire comfort e sostegno con leggerezza visiva. Proposto in una vasta gamma di materiali e colori, Jimmy si adatta con disinvoltura a contesti domestici e contract, aggiungendo sempre un tocco di stile rétro contemporaneo.

Inspired by the elegance of the 1950s, the **Jimmy** stool blends versatility, playful character, and a distinctly vintage soul.

Its hallmark feature lies in the soft, curved **cylinders** that shape the seat – an inviting, well-balanced form designed to offer both comfort and support with a light, sculptural presence. Available in a wide variety of colors and materials, Jimmy adapts effortlessly to both residential and contract settings, always adding a touch of contemporary retro charm.











# Snaked

/ Giuseppe Dicecca

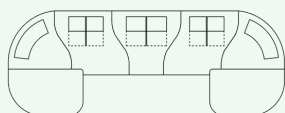

## Modular sofa

**Snaked** è un divano modulare pensato per dare forma a infinite composizioni, grazie agli 11 moduli disponibili e a una palette colori ricca e dinamica.

Il progetto si sviluppa attorno al tema della curva, filo conduttore che lega tra loro gli elementi e ne guida la **modularità**. Una libertà compositiva che consente di interpretare al meglio ogni spazio, adattandosi con eleganza a esigenze di forma e funzione. Il profilo in piping a contrasto ne valorizza le linee sinuose, aggiungendo un dettaglio di vivacità cromatica e sofisticata leggerezza.

---

**Snaked** is a modular seating system designed to express infinite combinations, thanks to its 11 versatile modules and a dynamic, expressive color palette.

The project is shaped by the language of curves — a visual and conceptual thread that unites each element through a fluid and elegant **modularity**. This design freedom allows for refined, tailor-made solutions that respond to diverse spatial and functional needs. Contrasting piping outlines its sculptural curves, adding a subtle yet vibrant accent of color and sophistication.







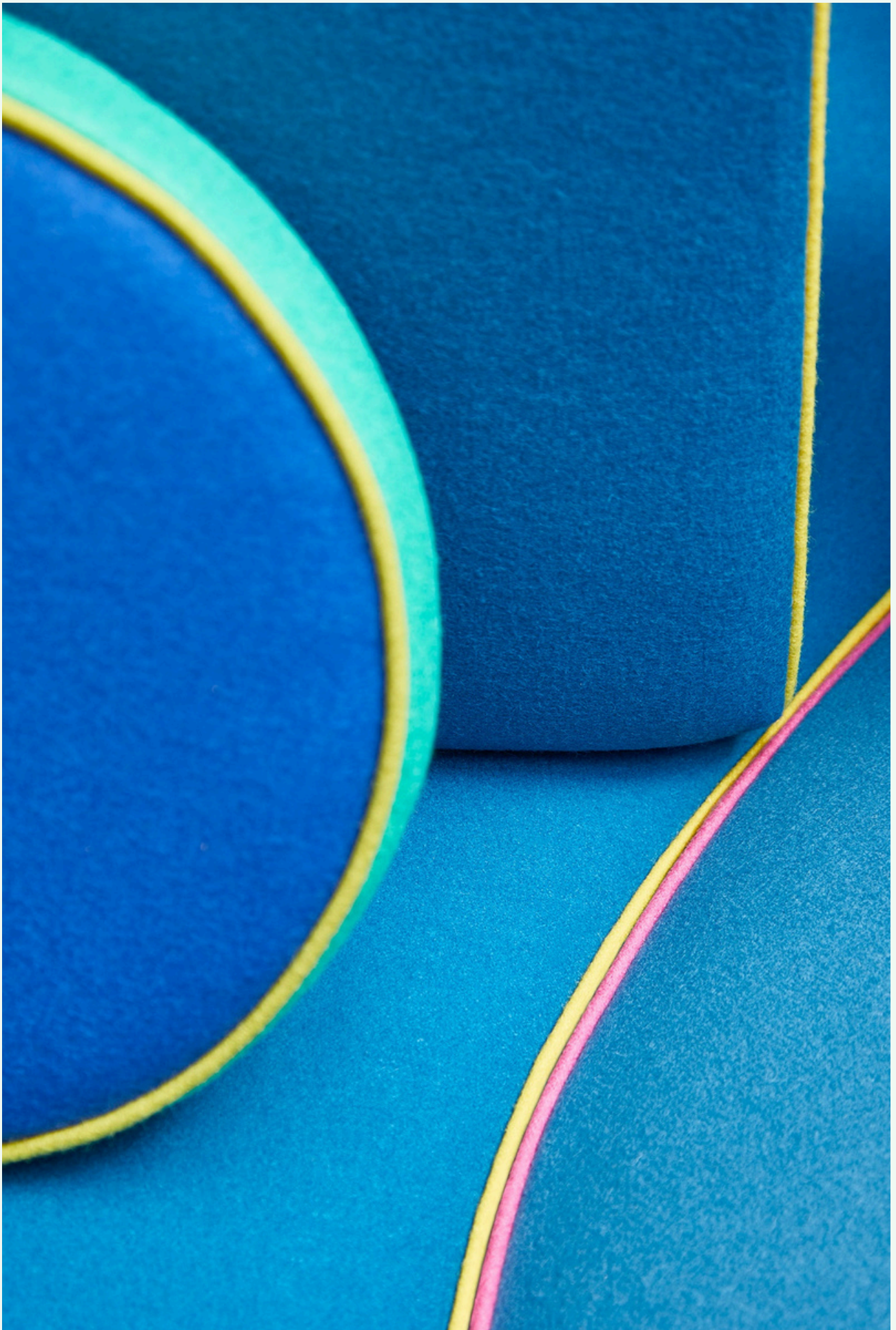



# Graphius

/ Giuseppe Dicecca

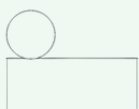

## Armchair / Modular sofa / Pouf

Un'eleganza **modulare** che si adatta con naturalezza agli spazi contemporanei.

La poltrona **Graphius** coniuga versatilità, alto artigianato fiorentino e un approccio sostenibile al design d'interni.

Ogni dettaglio è pensato con precisione, in linea con la filosofia della collezione, che celebra la modularità come segno distintivo.

Grazie alla sua struttura, Graphius si presta con flessibilità a diverse configurazioni, offrendo un comfort avvolgente e un'estetica essenziale e senza tempo.

---

**Modular** elegance that fits seamlessly into contemporary interiors.

The **Graphius** armchair blends versatility, refined Florentine craftsmanship, and a sustainable design ethos.

Every detail is carefully considered, in harmony with the collection's philosophy, which embraces modularity as a defining element.

Thanks to its structure, Graphius adapts effortlessly to a variety of configurations, offering enveloping comfort and a timeless, understated aesthetic.















# Tiamo

/ Giuseppe Dicecca

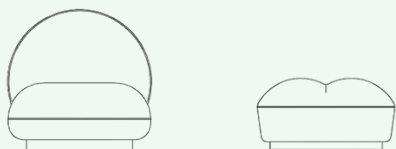

## Swivel Armchair / Lepouf

La poltrona **Tiamo** indoor rappresenta l'equilibrio ideale tra comfort e carattere.

Le sue linee morbide e avvolgenti, unite a una palette cromatica decisa e dal sapore rétro, conferiscono all'ambiente un'estetica pop e contemporanea, capace di infondere energia e leggerezza.

Progettata per garantire un comfort superiore, Tiamo è realizzata con imbottiture ad alta densità e rivestimenti di pregio, pensata per offrire un'esperienza avvolgente e duratura nel tempo.

La scelta perfetta per chi cerca uno stile **iconico** e accogliente, ideale per living raffinati, lounge di hotel e spazi di rappresentanza.

The **Tiamo** indoor armchair embodies the perfect balance between comfort and character.

Its soft, enveloping lines, combined with a bold, retro-inspired color palette, bring a pop and contemporary aesthetic that energizes and lightens any space.

Designed to deliver superior comfort, Tiamo features high-density padding and premium upholstery, crafted to provide a lasting, embracing seating experience.

The ideal choice for those seeking an **iconic** and inviting style, perfect for sophisticated living rooms, hotel lounges, and prestigious reception areas.















# Tiamo

/ Giuseppe Dicecca

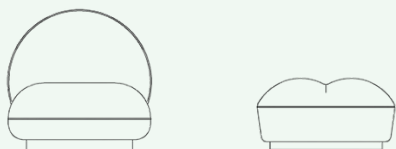

## Swivel Armchair / Lepouf

La poltrona **Tiamo** outdoor rappresenta l'incontro perfetto tra comfort e allegria, grazie alle sue linee morbide e tondeggianti e ai colori vivaci dal gusto vintage.

Un design pop e contemporaneo che dona freschezza a ogni ambiente esterno.

Il suo comfort eccezionale è garantito dall'innovativa gommapiuma **Dryfeel**<sup>®</sup>, una struttura a celle aperte che facilita il rapido drenaggio di acqua e umidità, assicurando il massimo benessere anche nelle condizioni più umide.

Tiamo è la scelta ideale per chi cerca uno stile unico e funzionale dedicato all'outdoor.

---

The **Tiamo** outdoor armchair is the perfect blend of comfort and cheerfulness, with its soft, rounded lines and vibrant vintage-inspired colors.

A pop and contemporary design that brings a fresh touch to any outdoor setting.

Its exceptional comfort is ensured by the innovative **Dryfeel**<sup>®</sup> foam – an open-cell structure that allows water and moisture to drain quickly, guaranteeing maximum wellbeing even in the wettest conditions.

Tiamo is the ideal choice for those seeking a unique and practical style for outdoor living.











PAOLONESI

**Informazioni tecniche / Technical details**

# Snaked

/ Giuseppe Dicecca

**Modular Sofa / Indoor**



Easy removable



Fireproof



Outdoor



Modular



Indoor

## BLOCCO 1

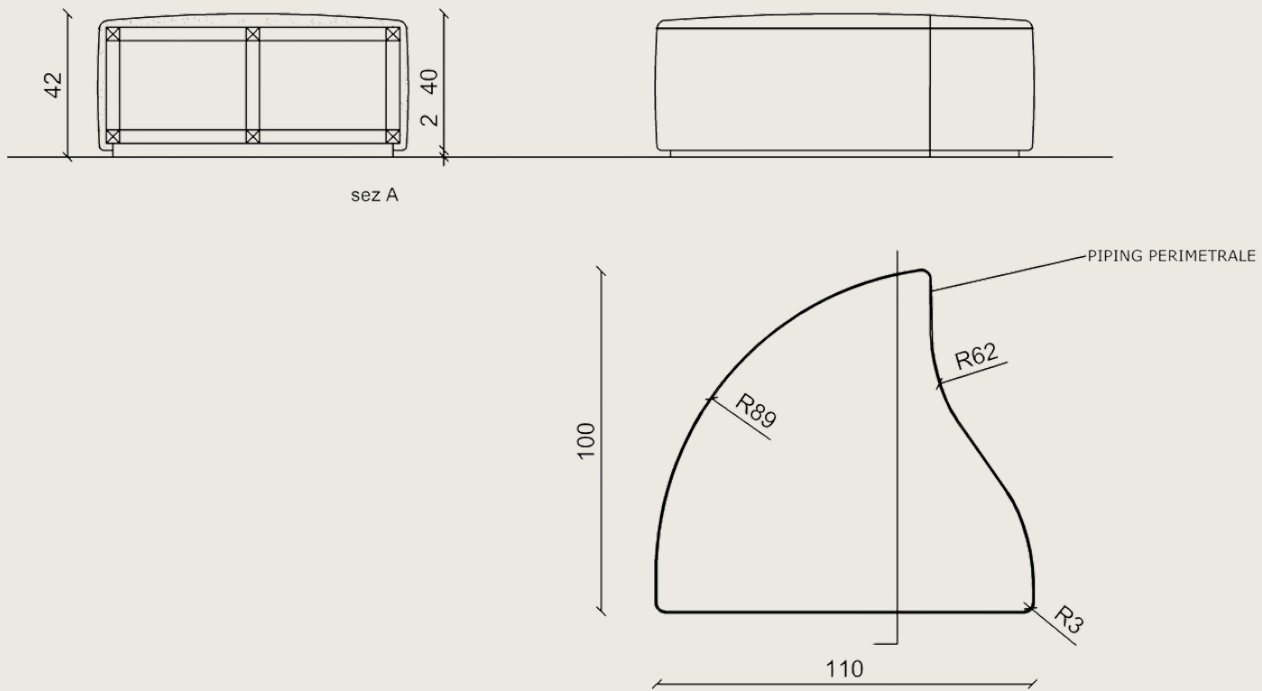

## BLOCCO 2

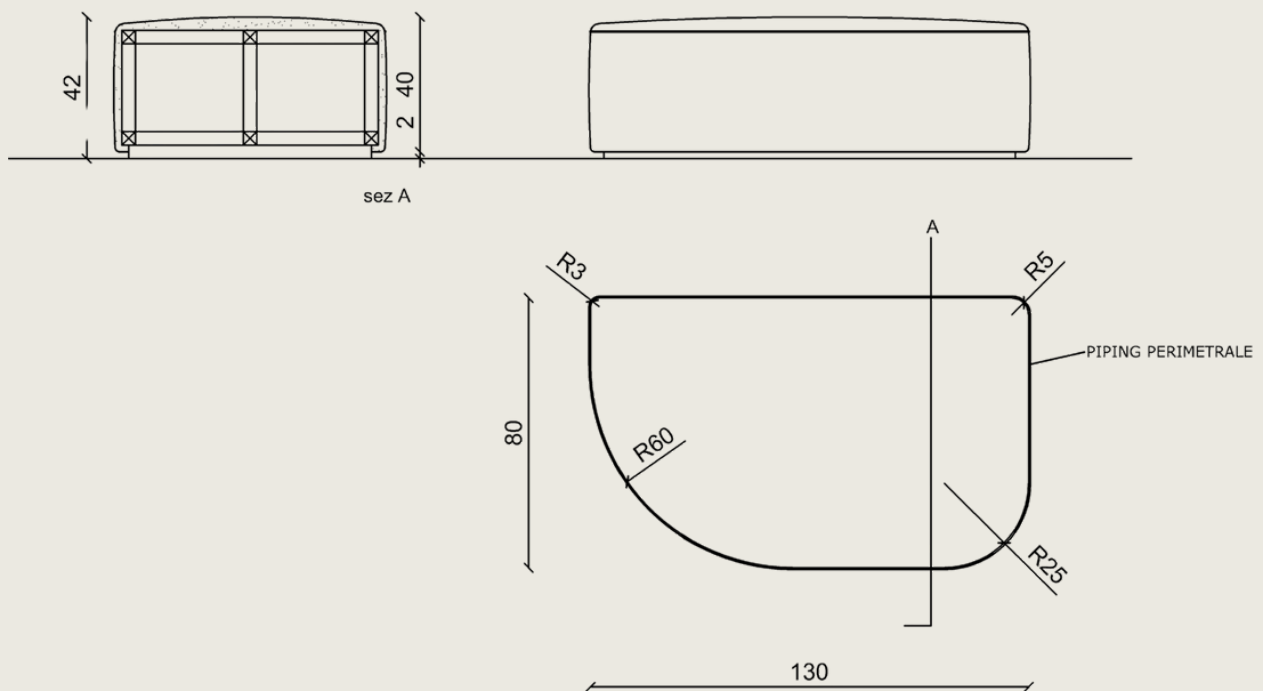

### BLOCCO 3

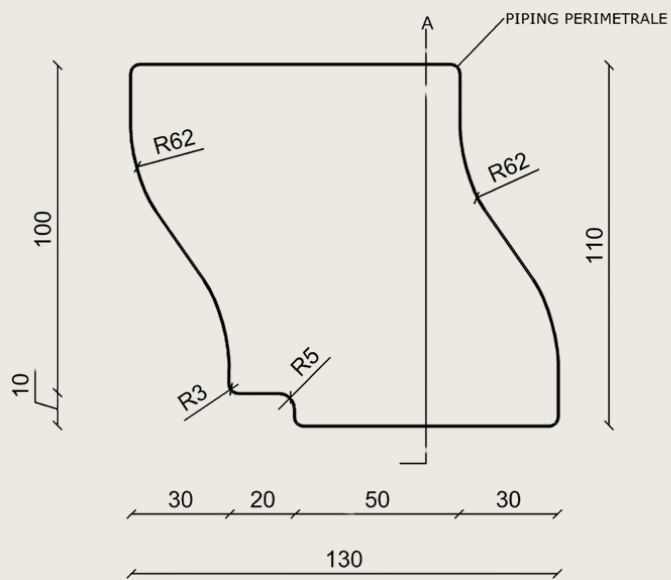

### BLOCCO 4

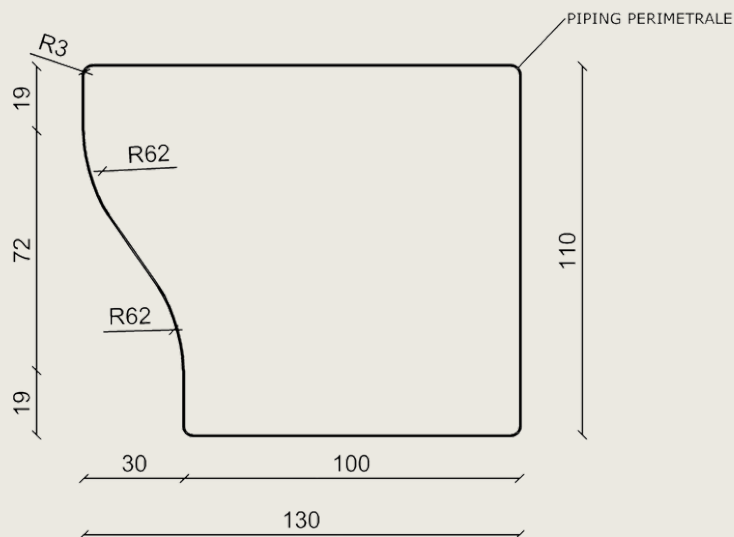
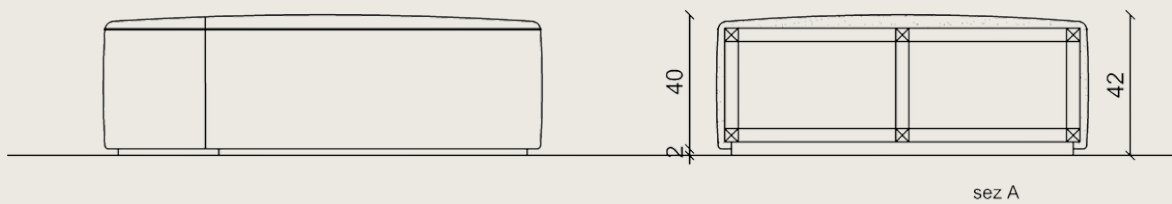

### BLOCCO 5

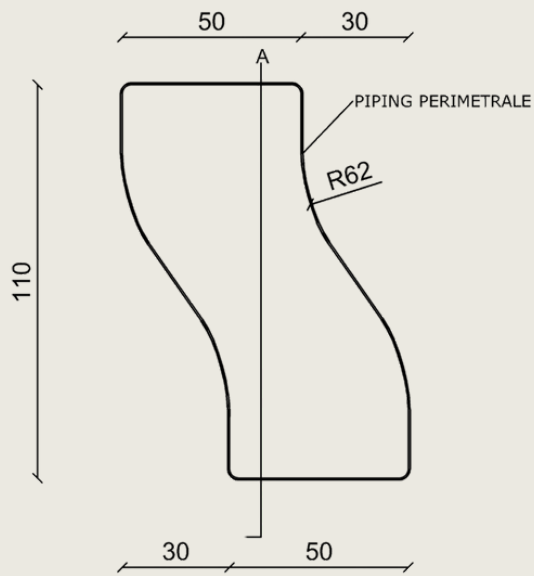
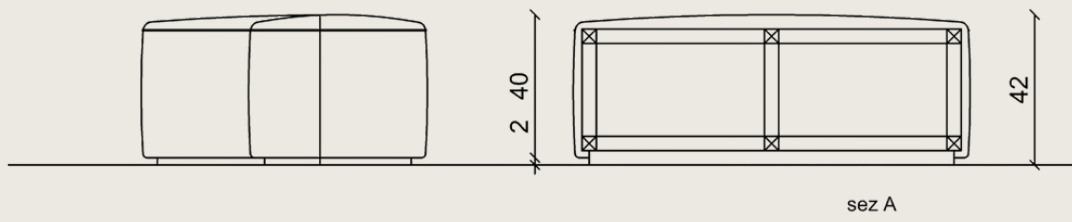

### BLOCCO 6

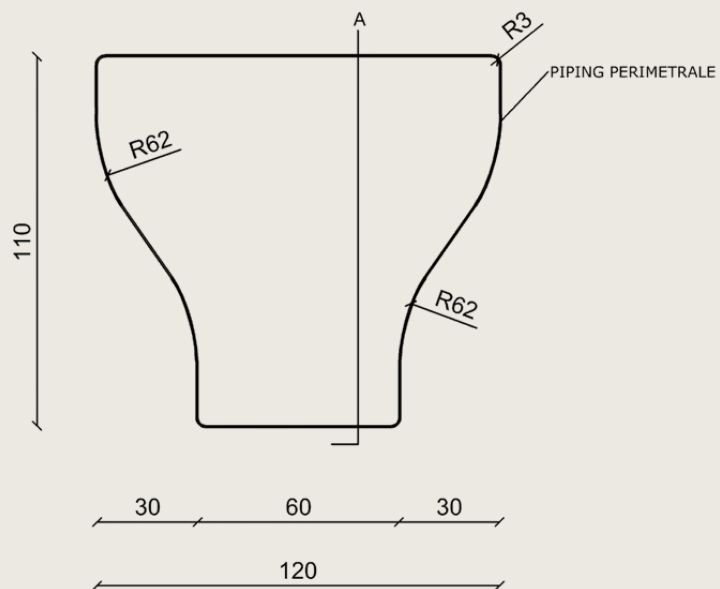
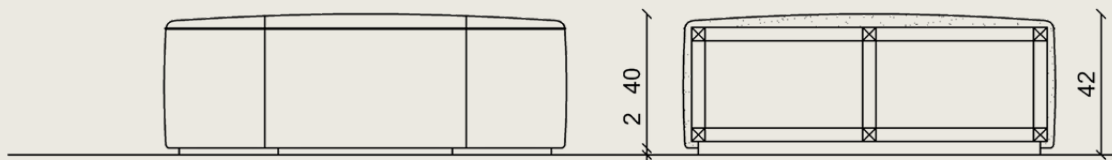

### BLOCCO 7

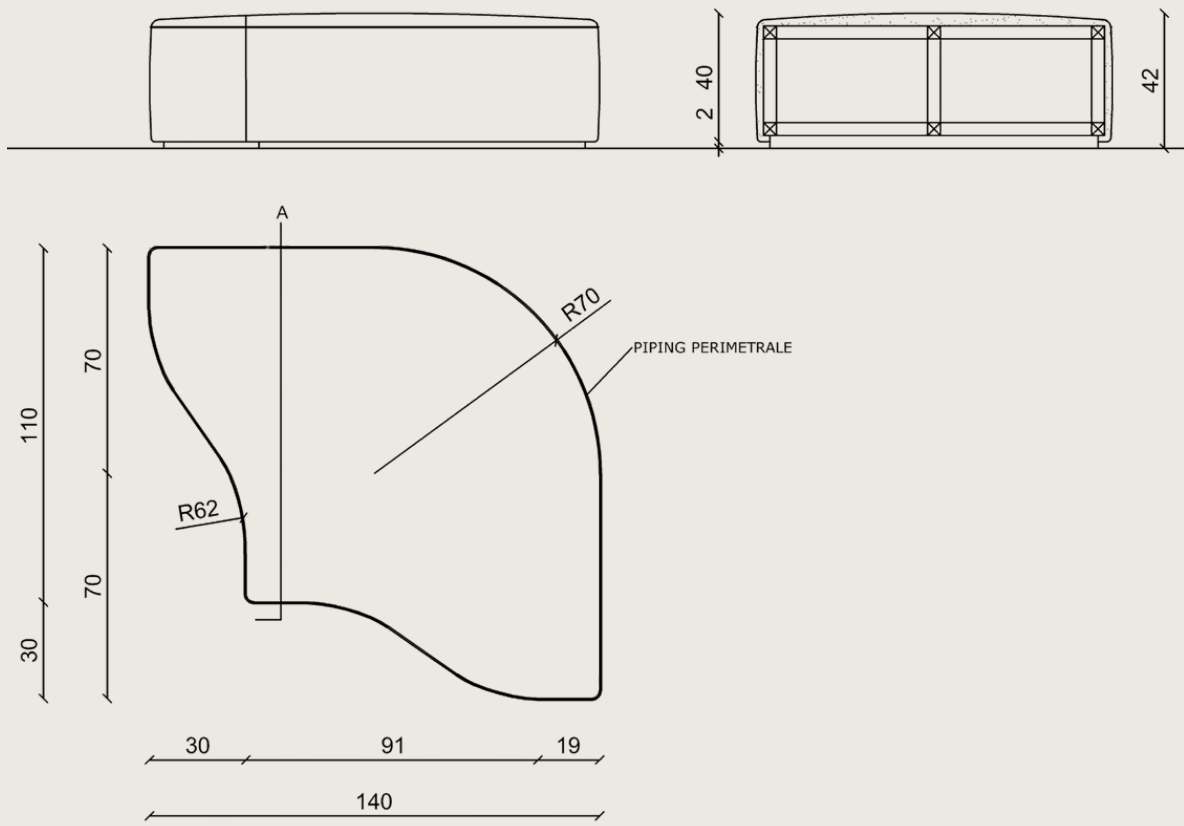

### BLOCCO 8

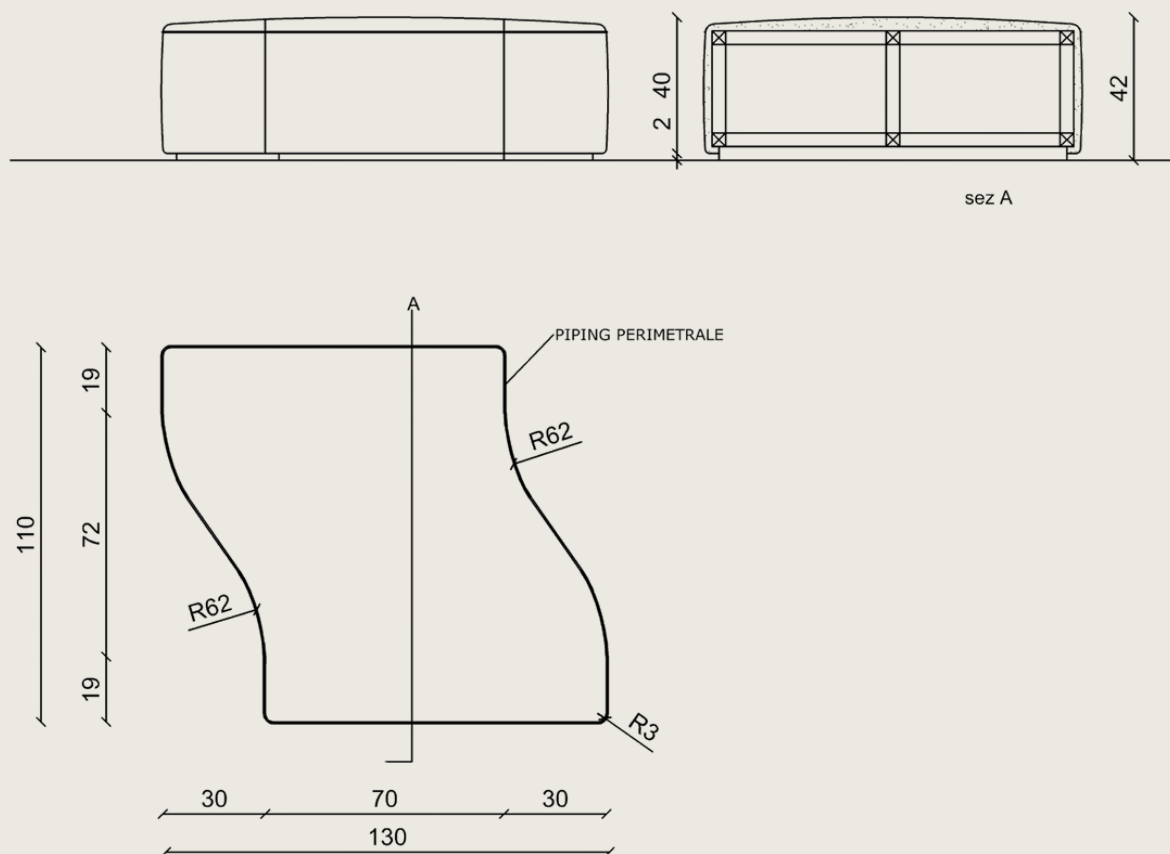

### BLOCCO 9

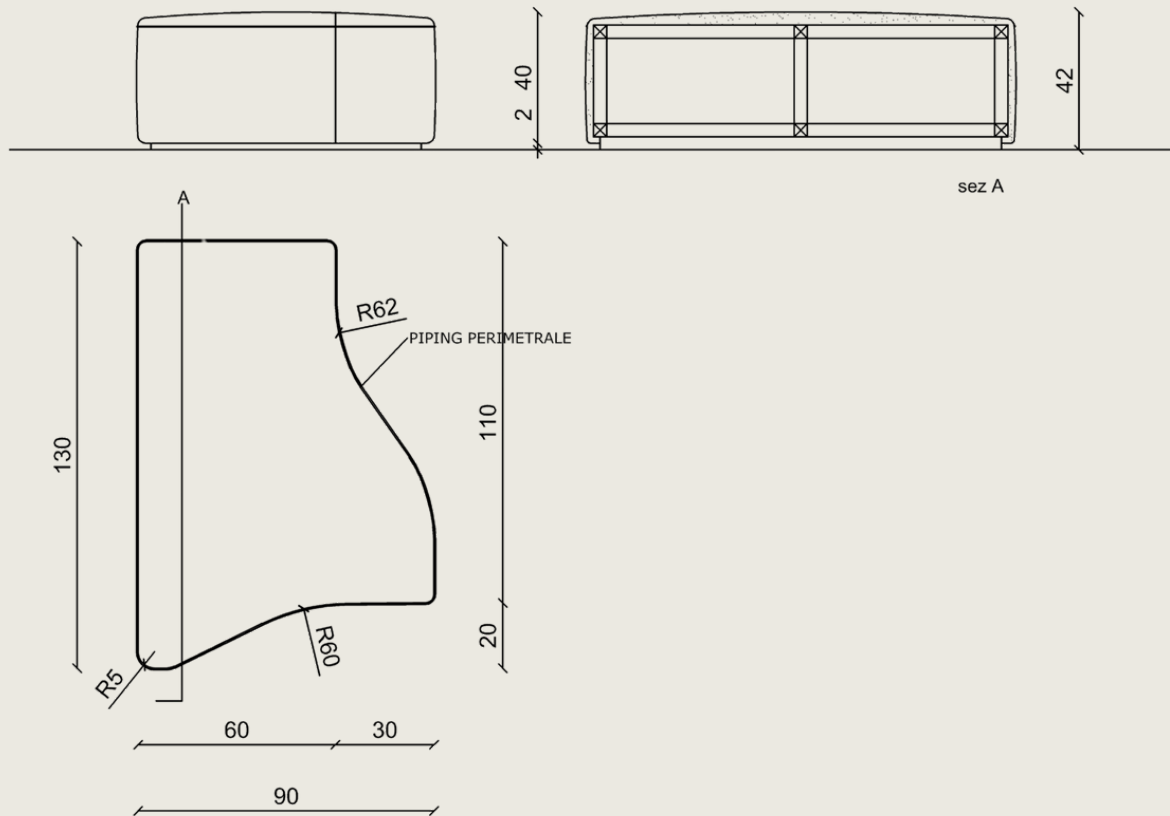

### BLOCCO 10

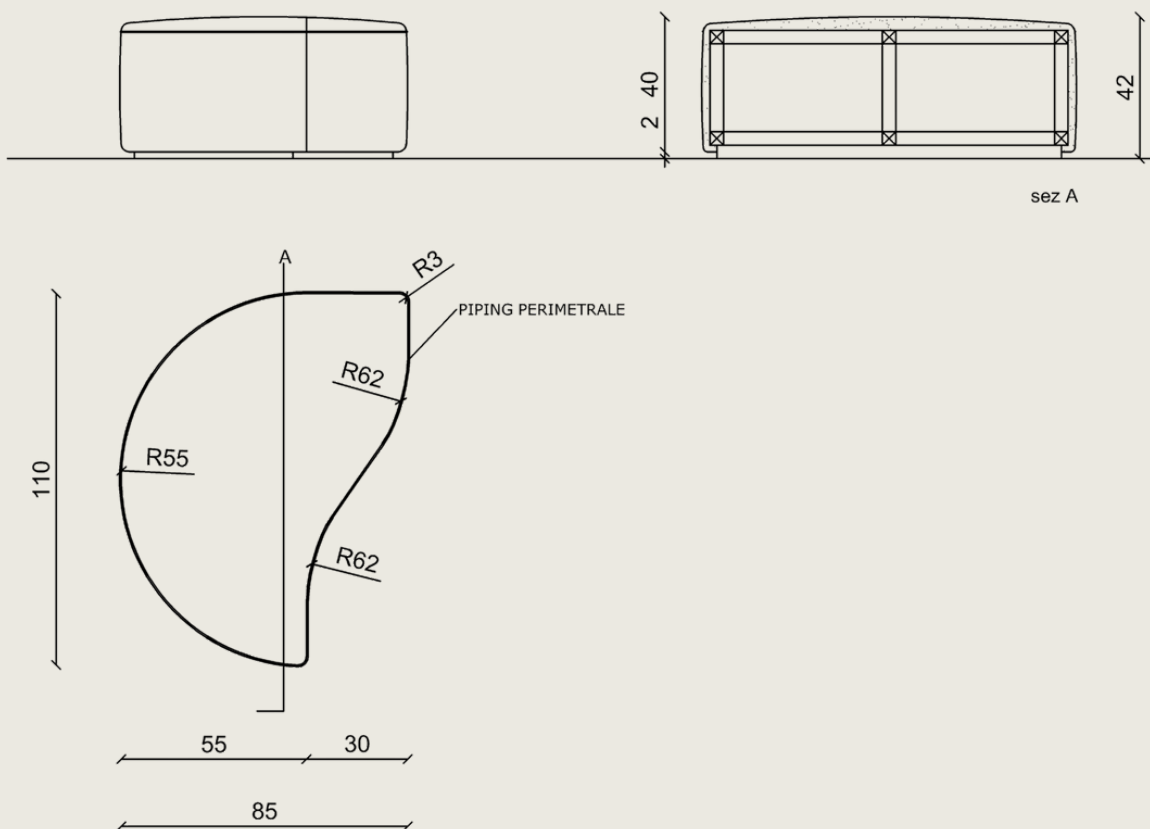

# BLOCCO 11

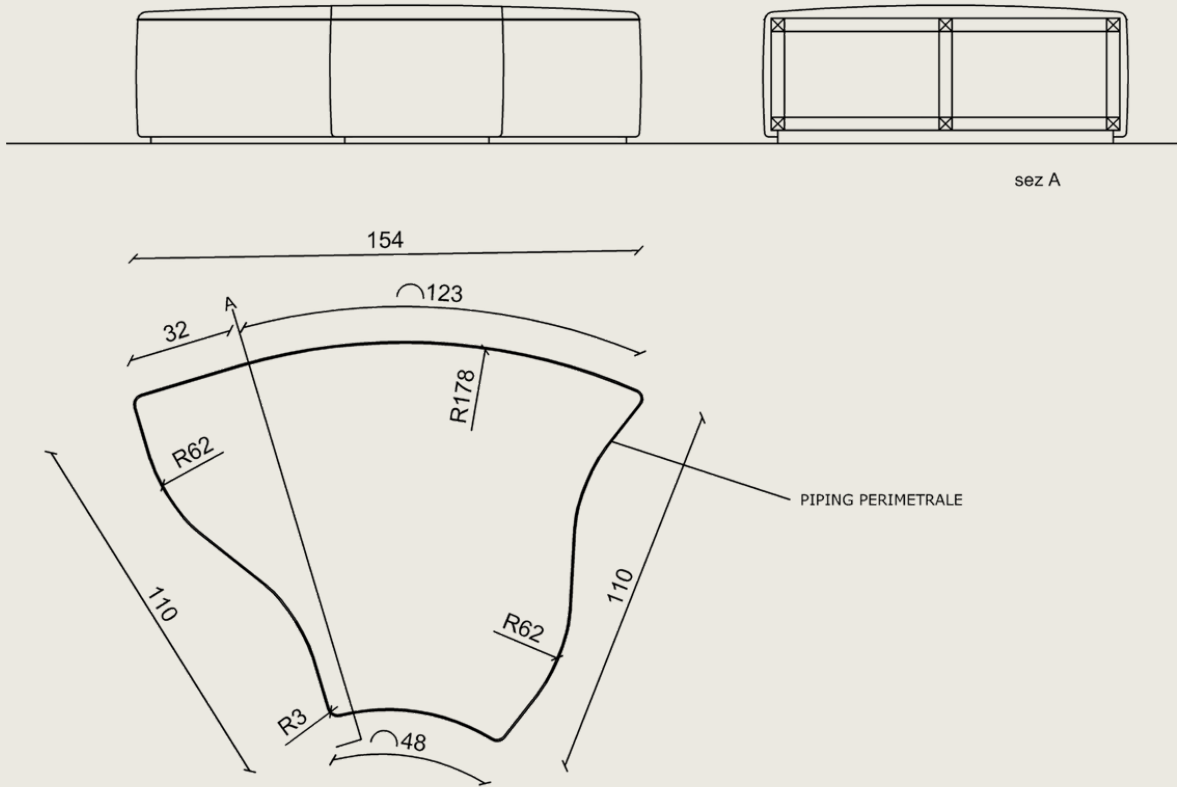

# BLOCCO 12

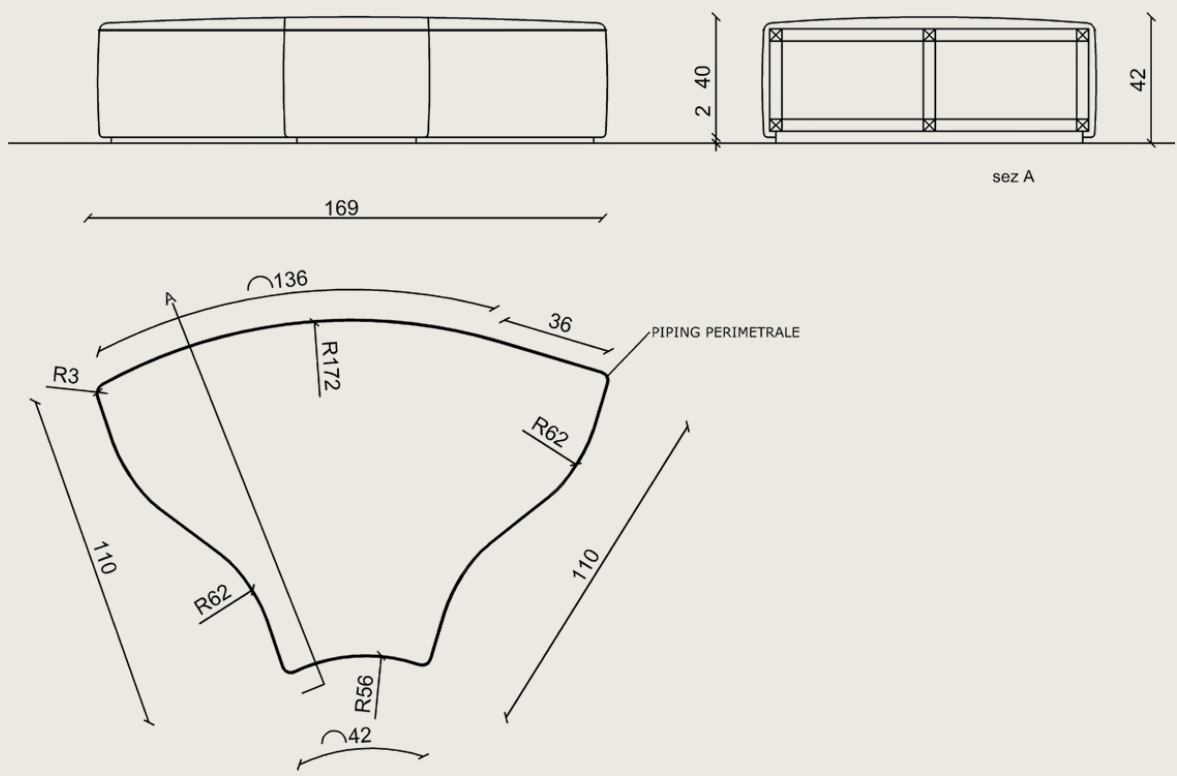

## SCHIENALE

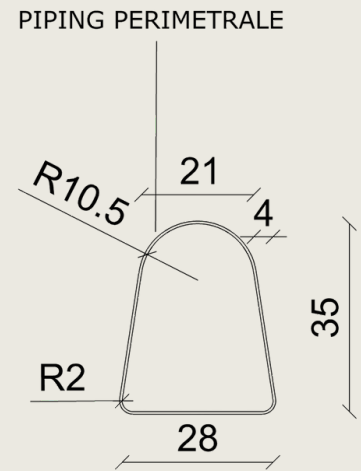

## SCHIENALE CURVO

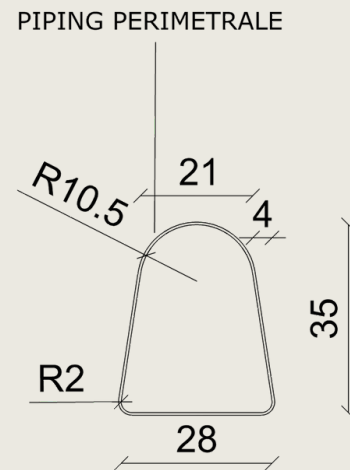

## SUPPORTO LOMBARE

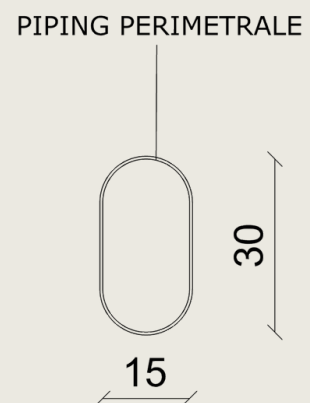

# Tiamo

/ Giuseppe Dicecca

## Swivel Armchair



Outdoor



Fireproof



Indoor

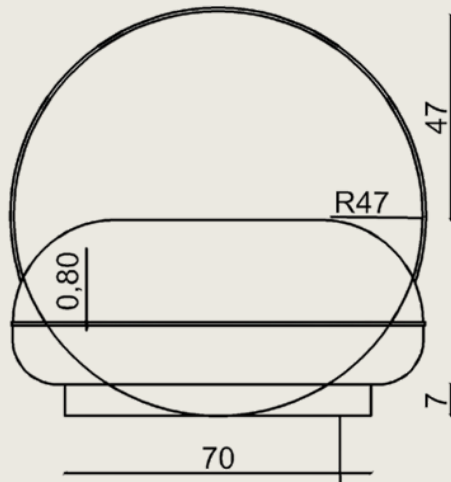

BASE GIREVOLE IN ACCIAIO VERNICIATO A POLVERE

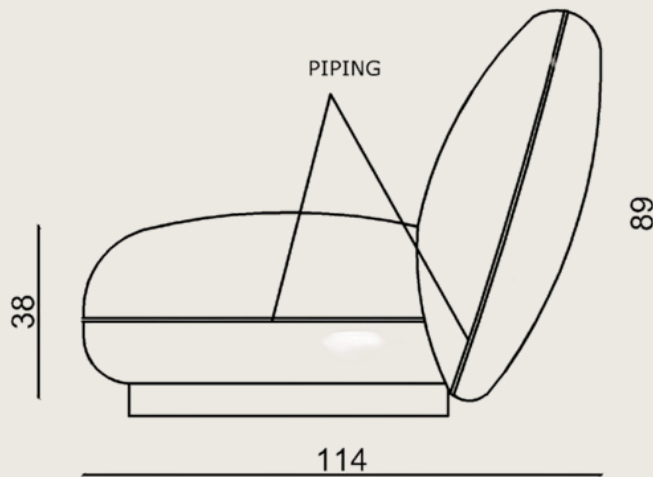
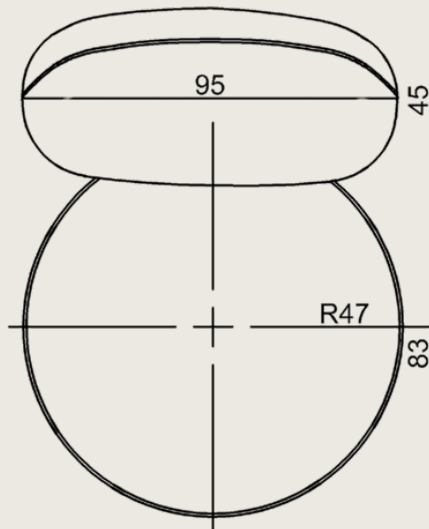

# Lepouf

/ Giuseppe Dicecca

## Pouf



 Outdoor

 Fireproof

 Indoor

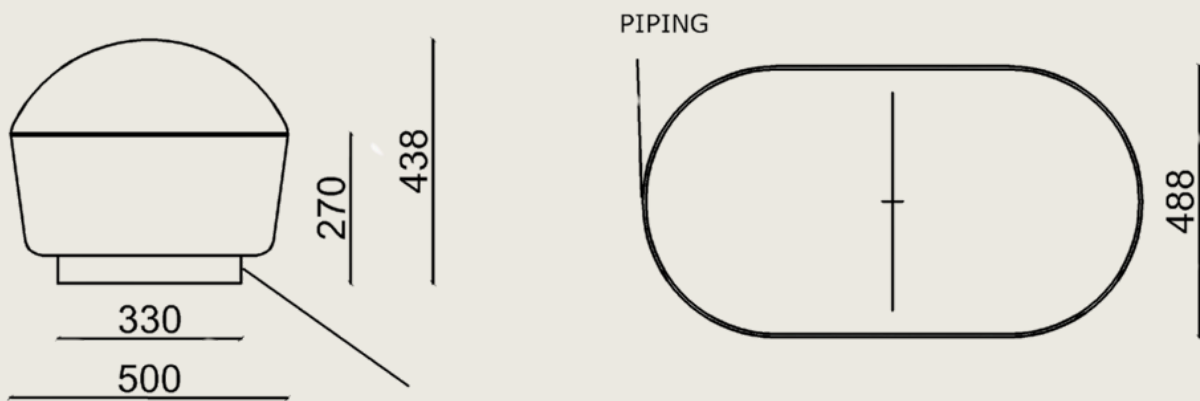
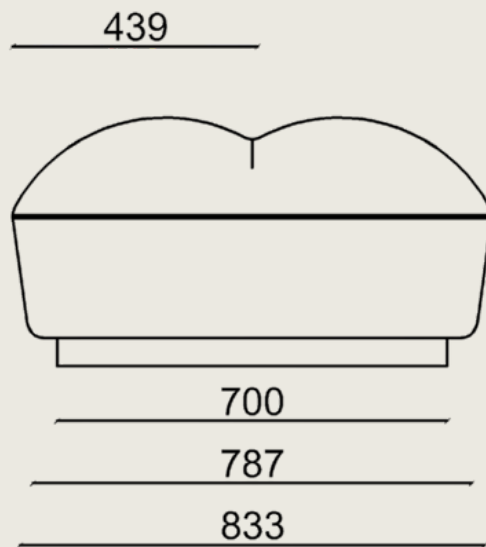

BASE IN ACCIAIO INOX VERNICIATA A POLVERE

# Misstake

/ Giuseppe Dicecca

Sofa / Indoor



Indoor



Fireproof

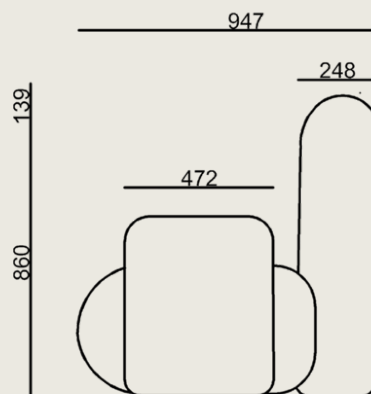
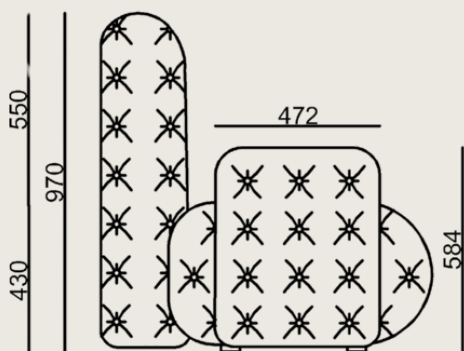
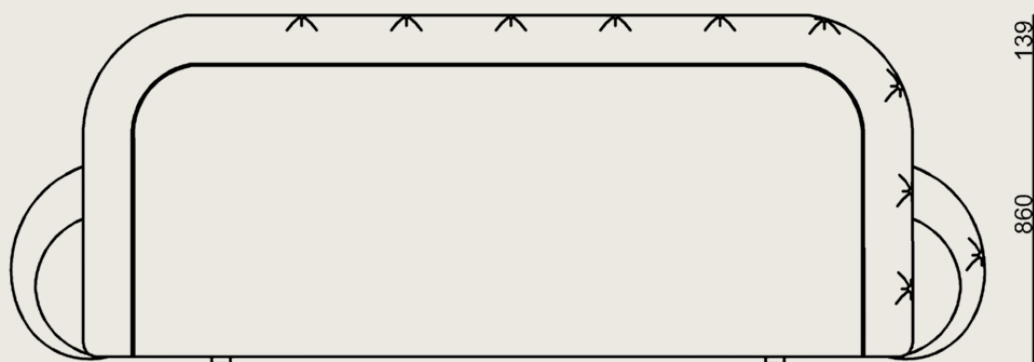
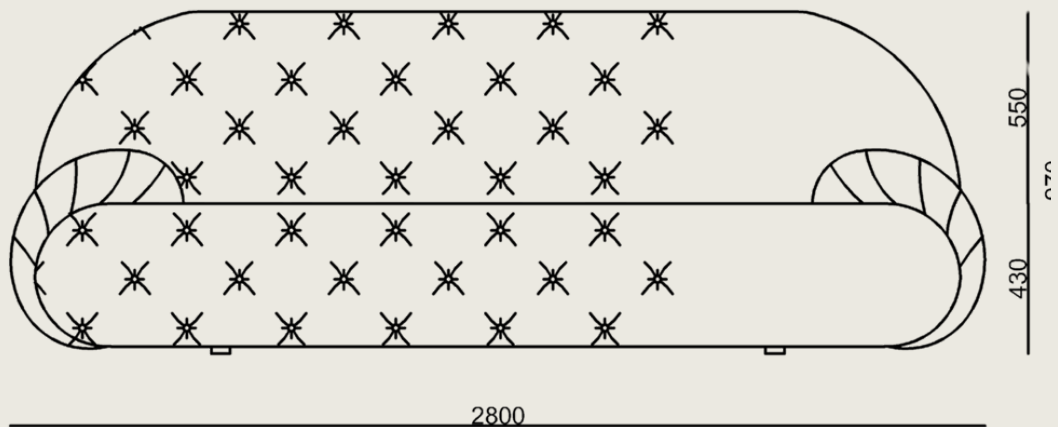

# Graphius

/ Giuseppe Dicecca

**Modular Sofa/ Big Pouf/ Mini Pouf**



 Indoor

 Fireproof

 Modular

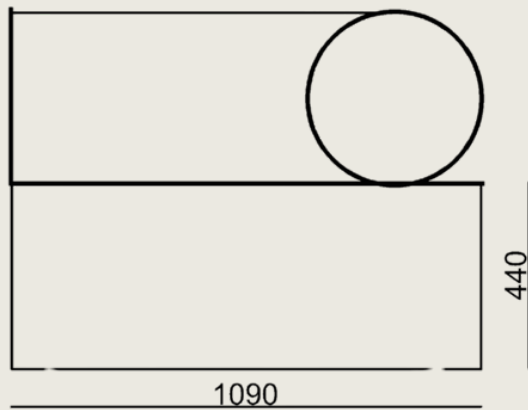
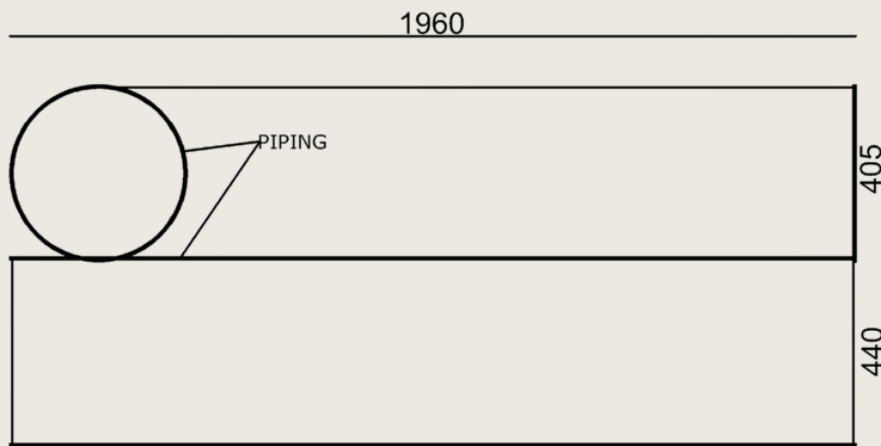
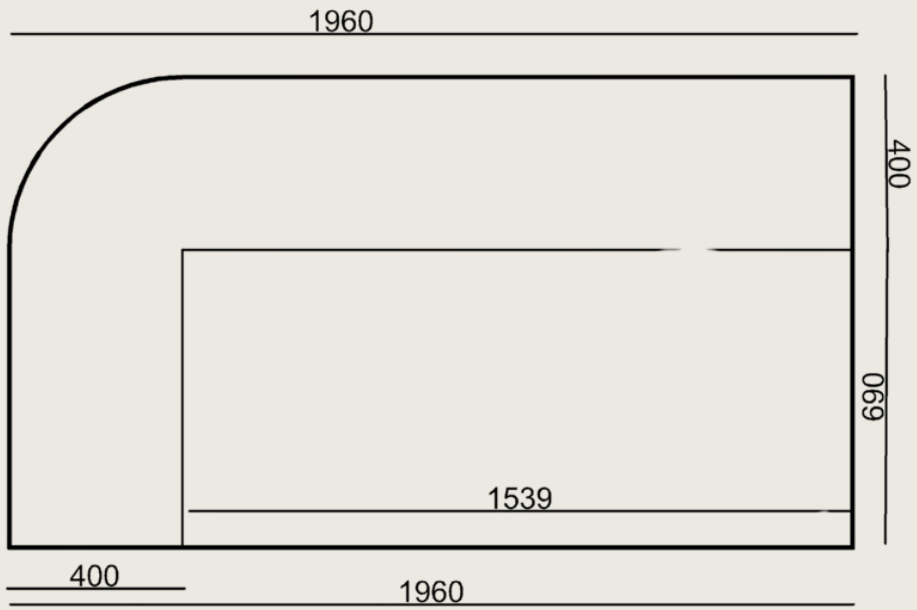

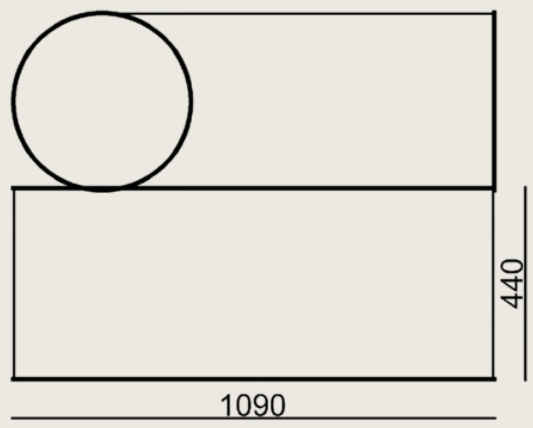
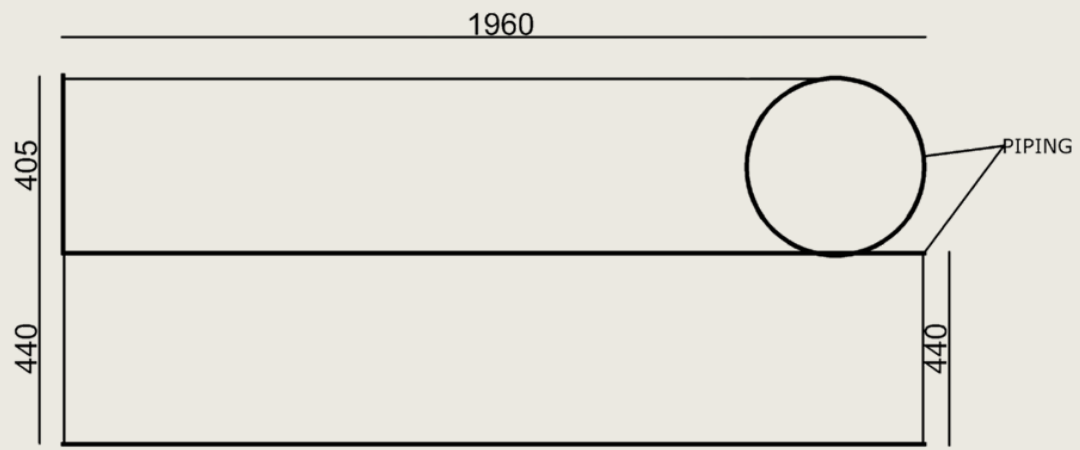
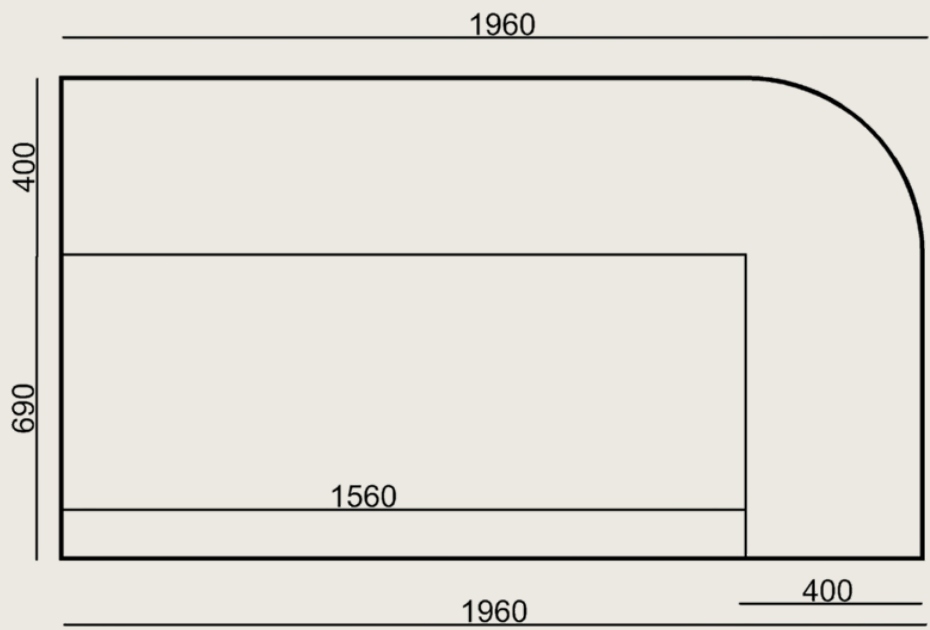

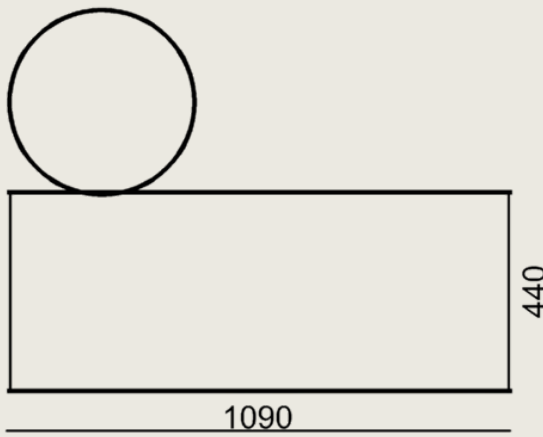
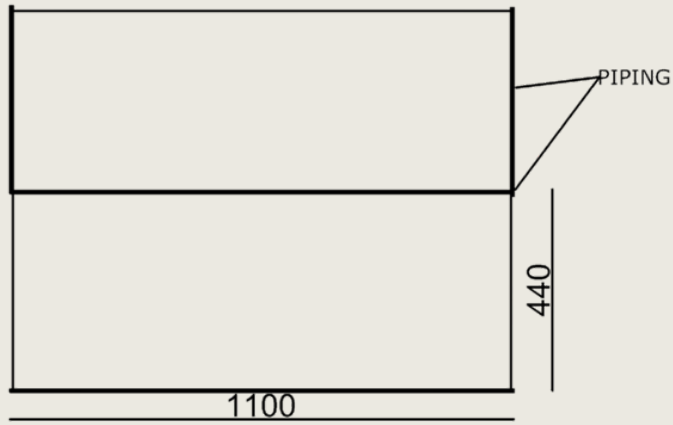
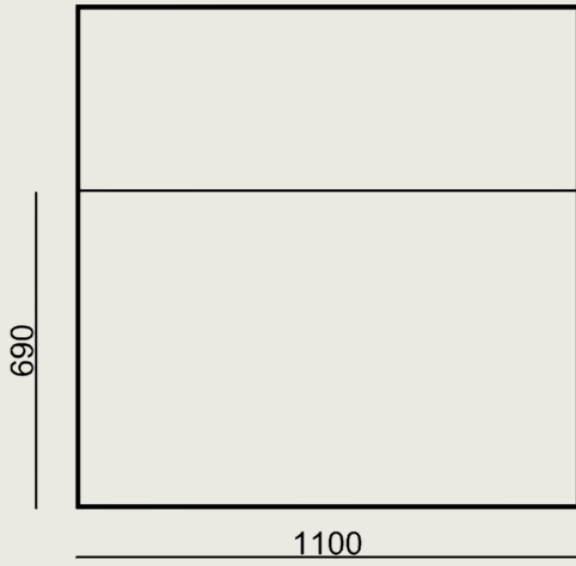

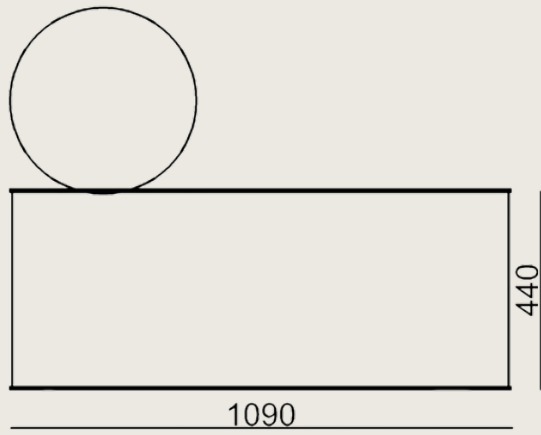
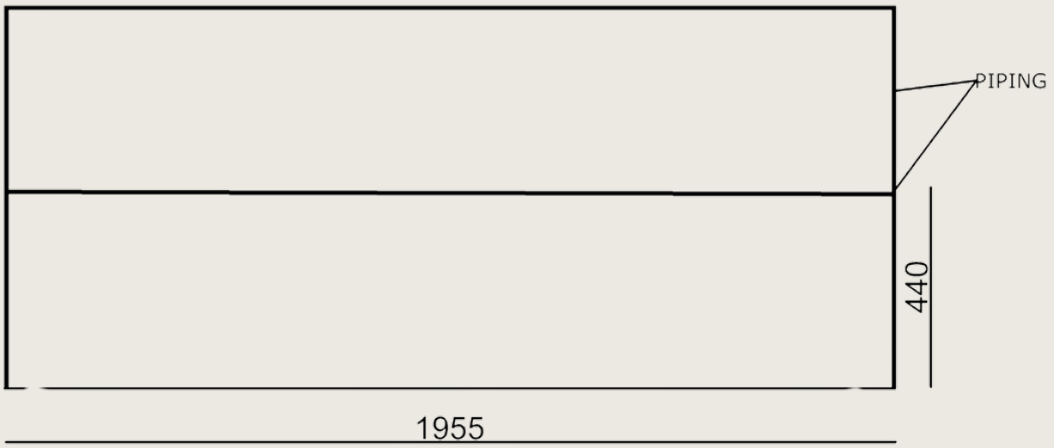
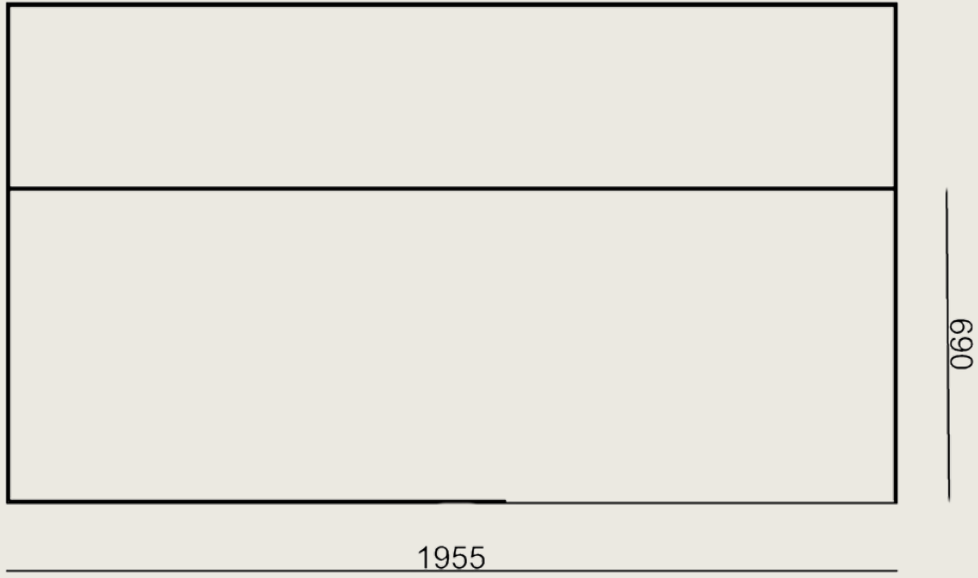

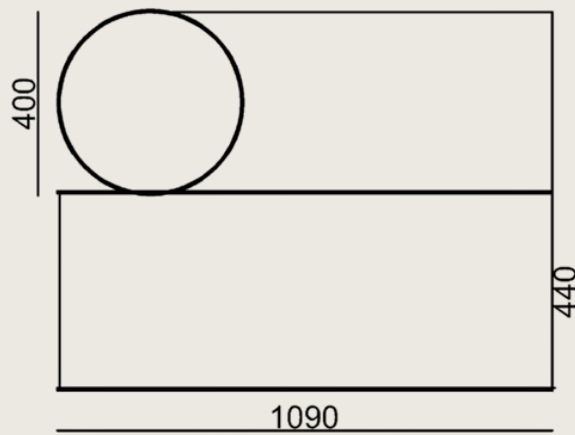
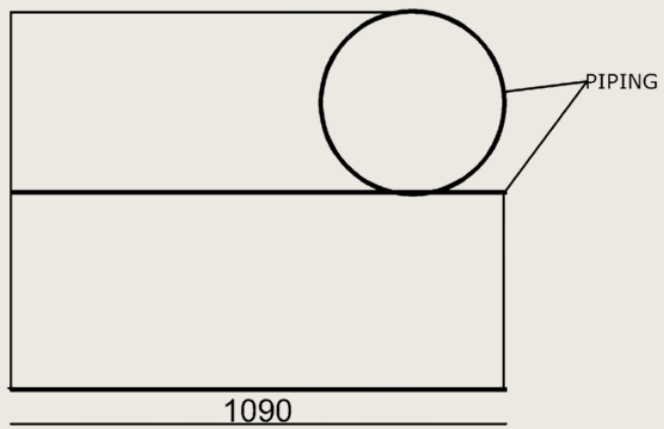
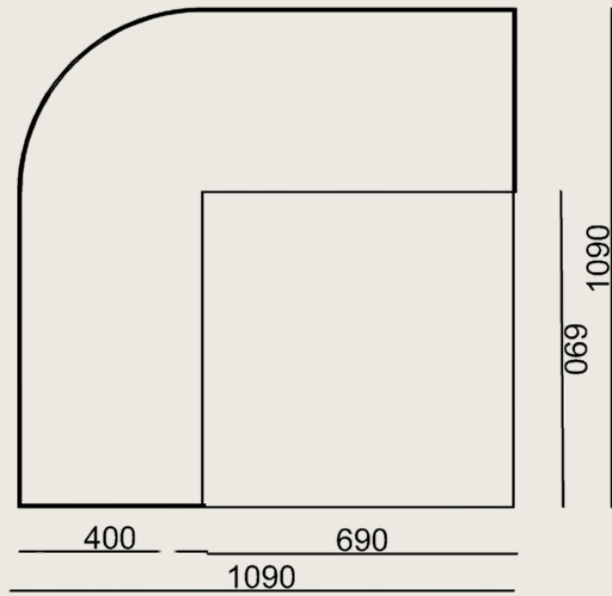

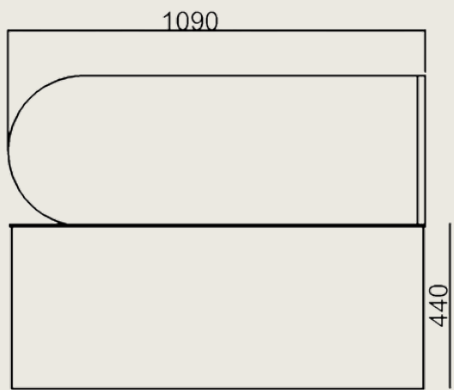
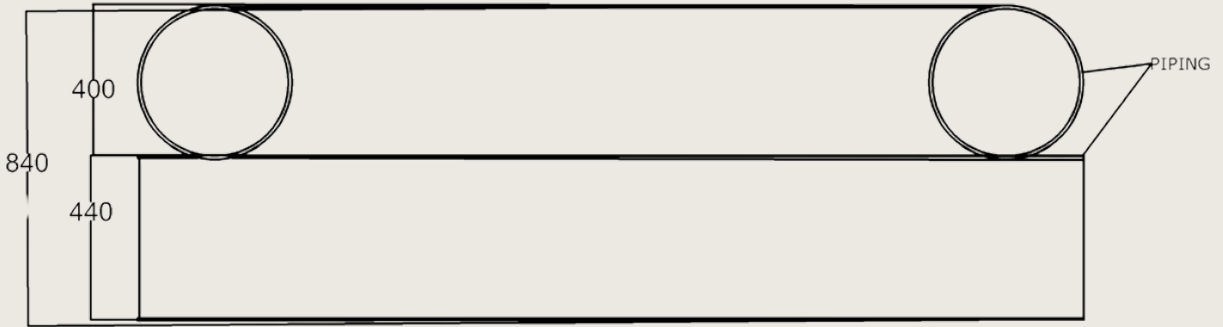
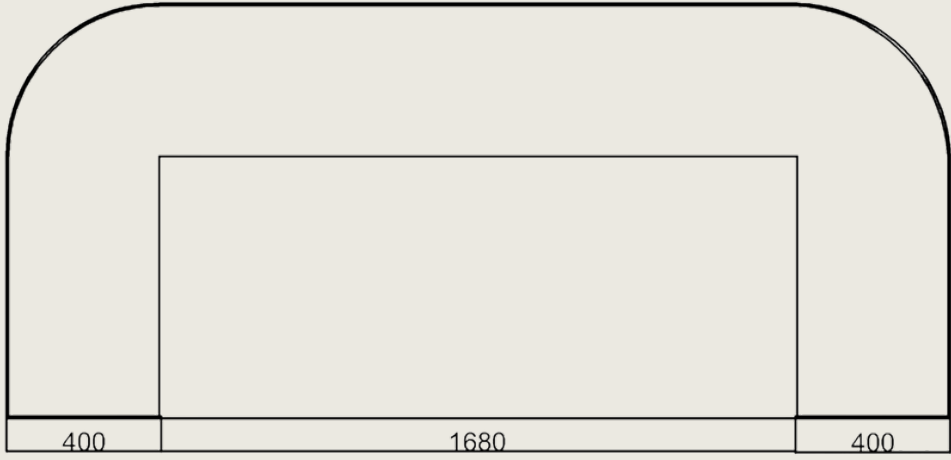

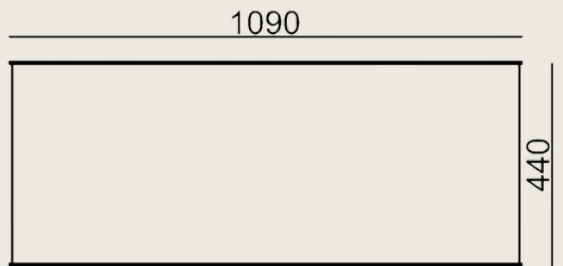
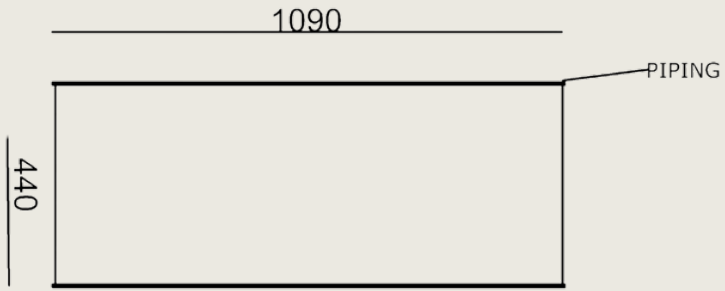
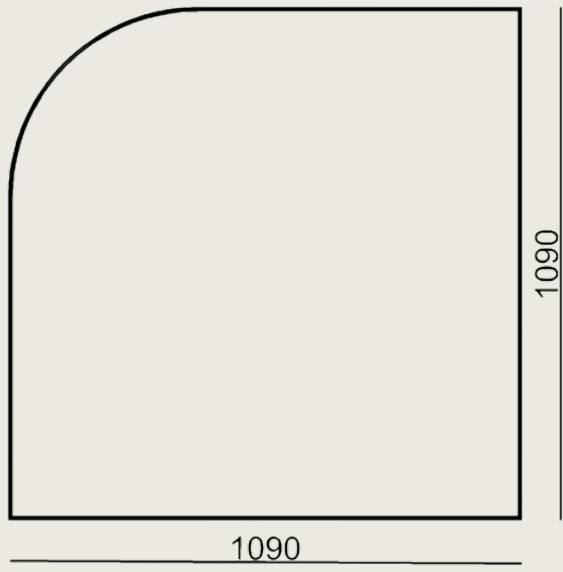

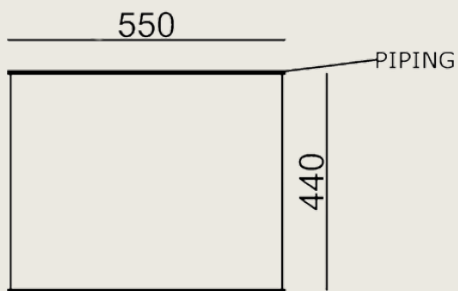
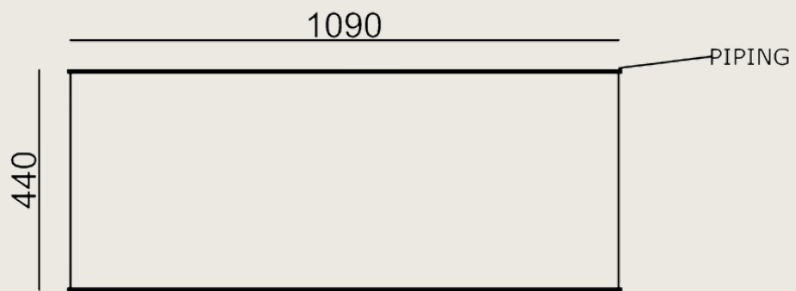
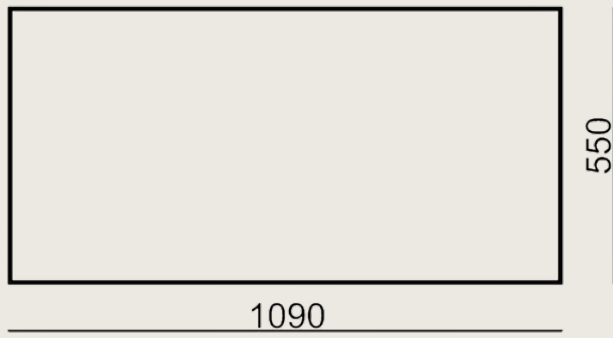



PAOLONESI

# Graphius globe

/ Giuseppe Dicecca

**Modular Sofa/ Big Pouf/ Mini Pouf**



 Outdoor

 Fireproof

 Indoor

 Modular

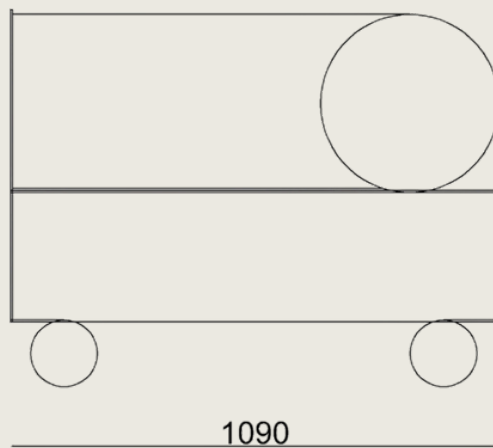
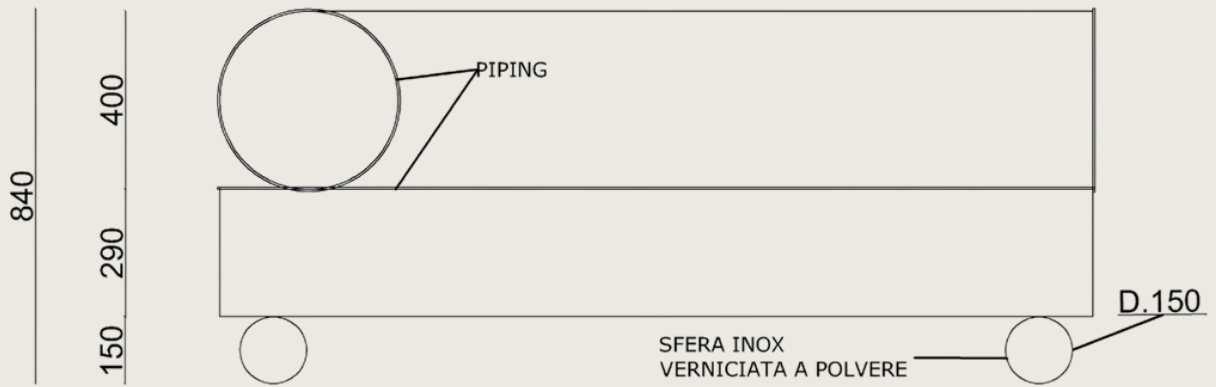
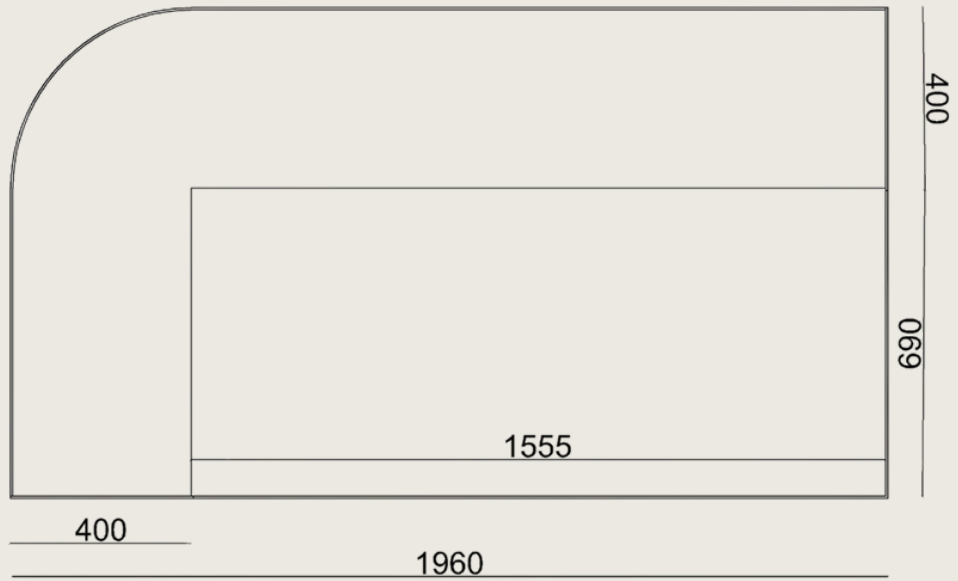

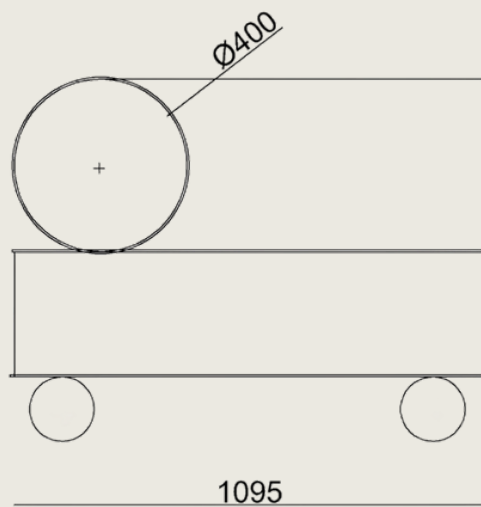
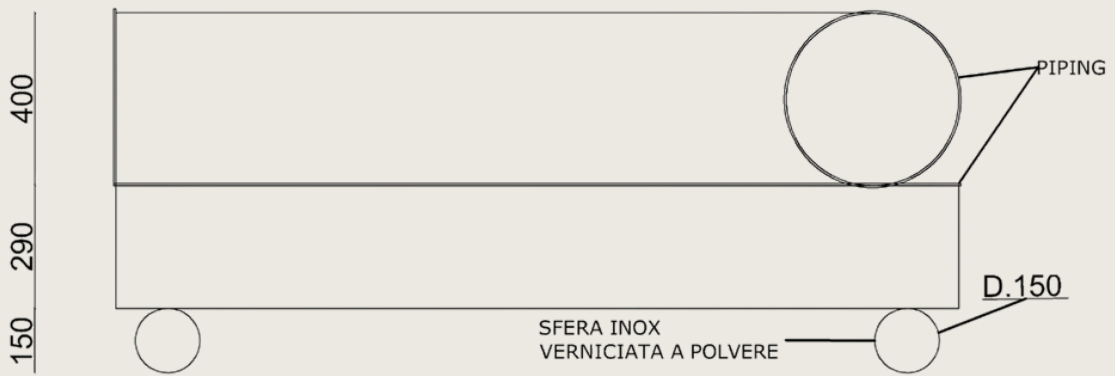
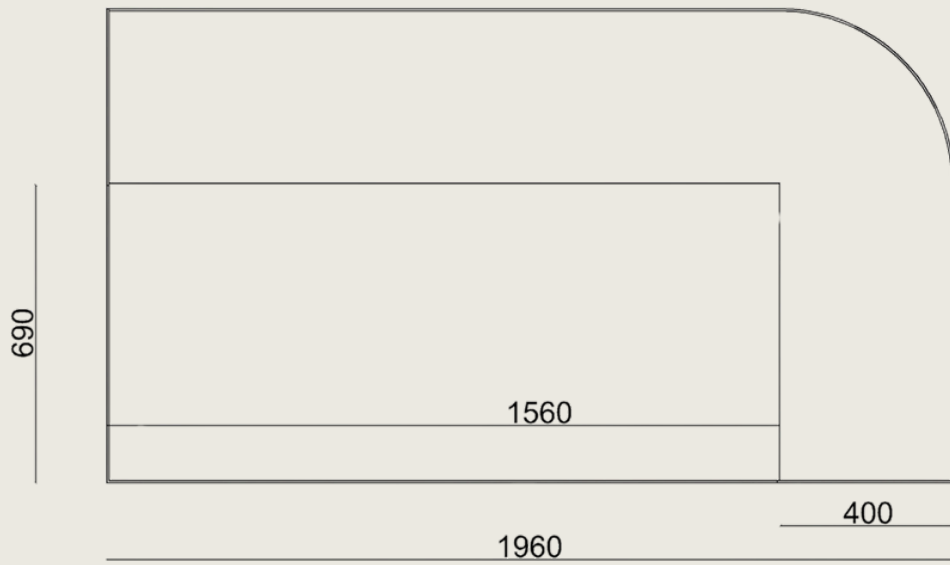

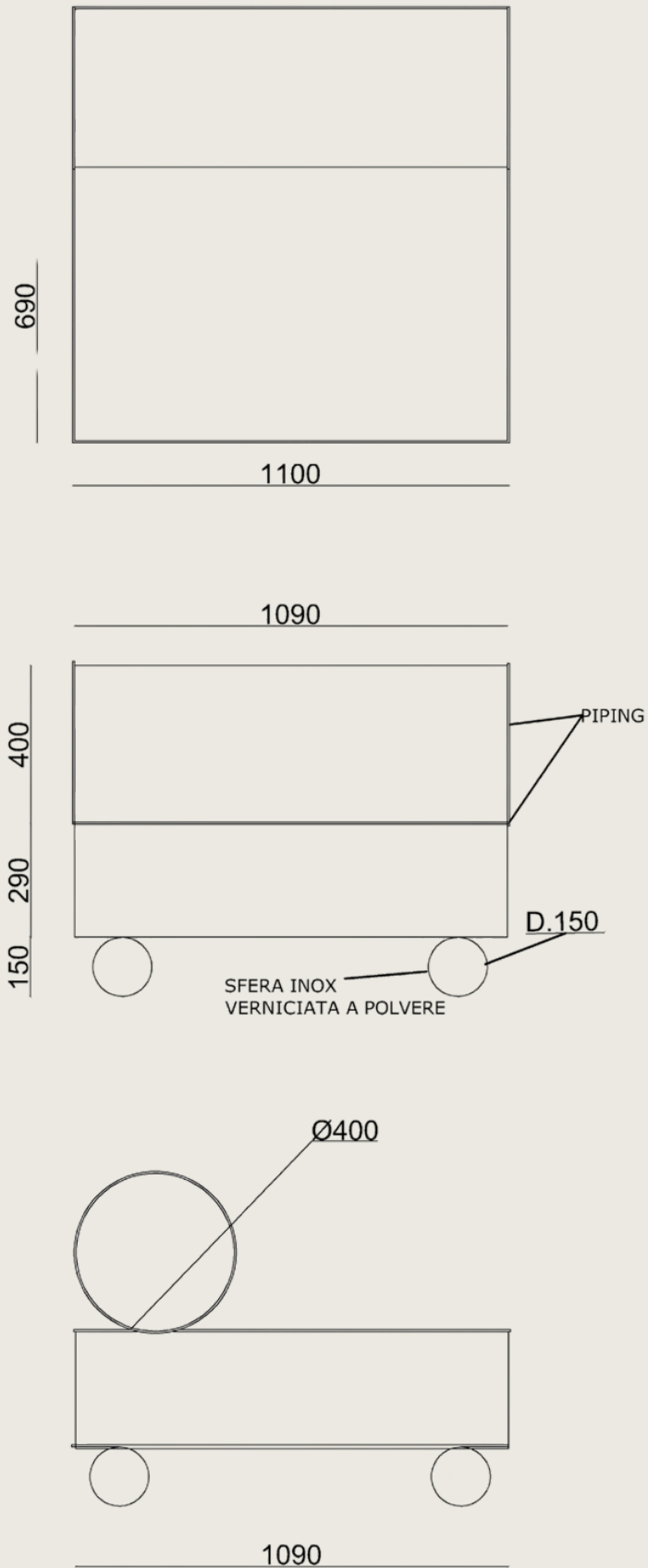

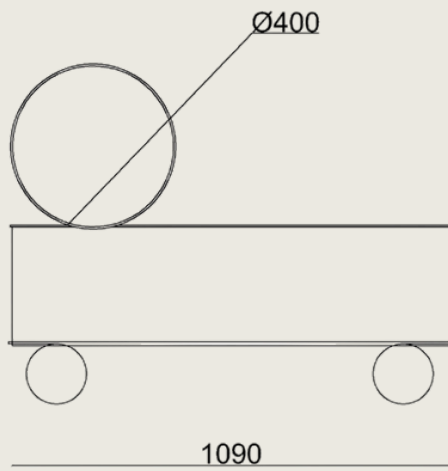
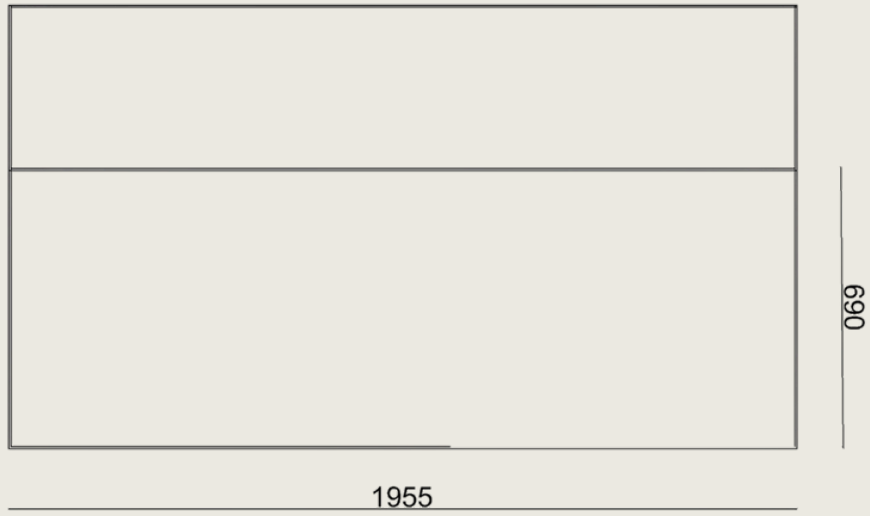

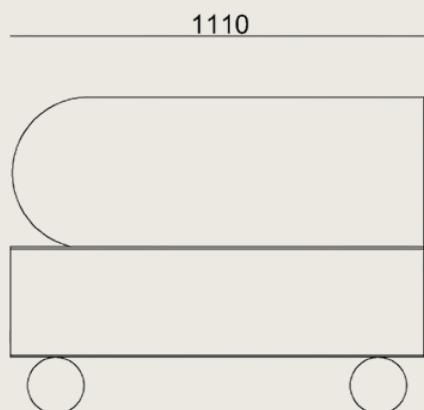
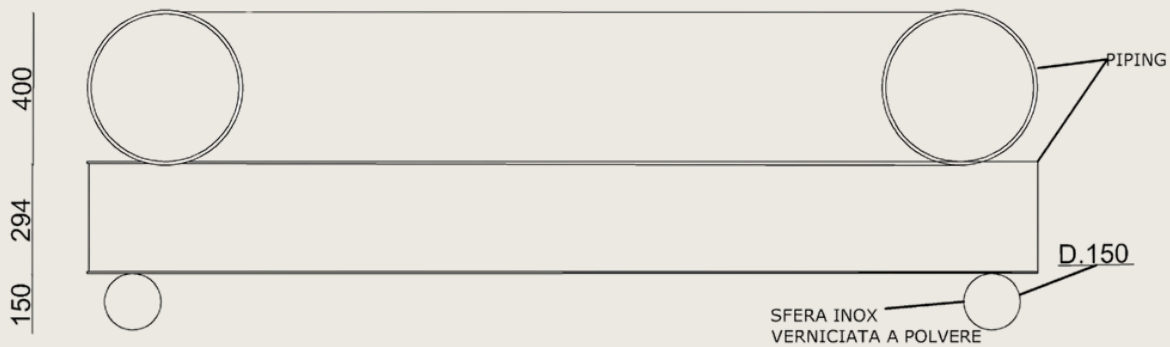
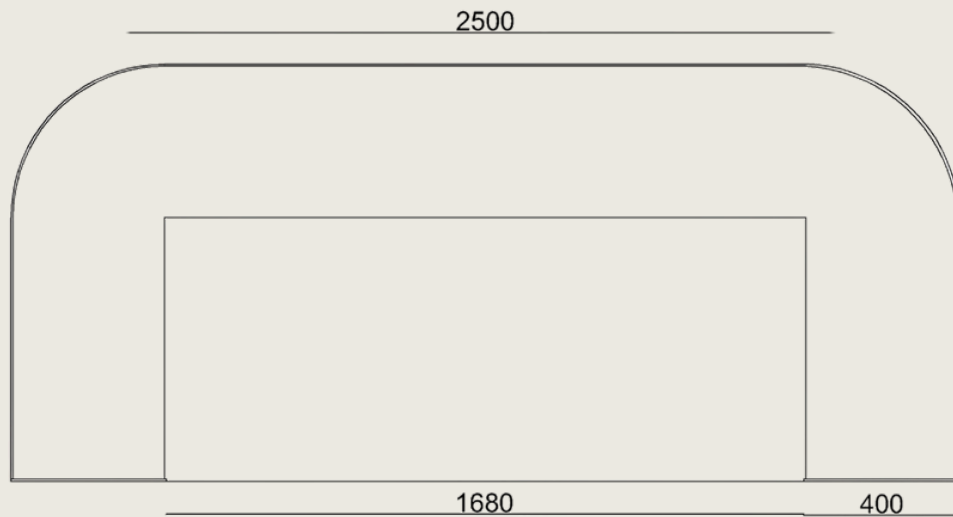

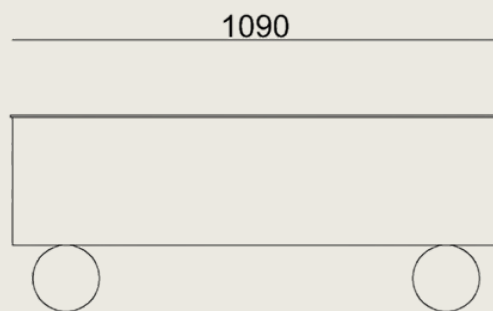
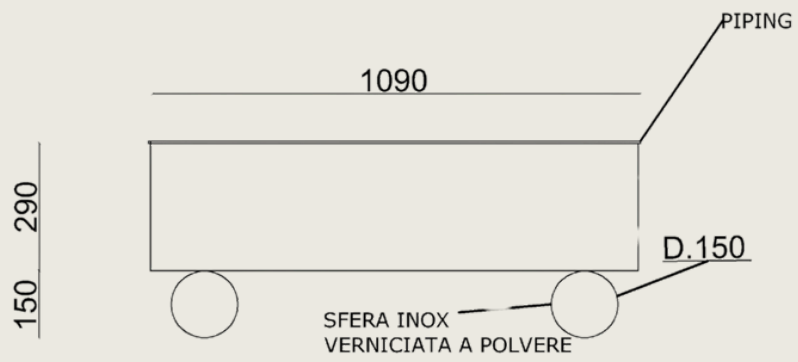
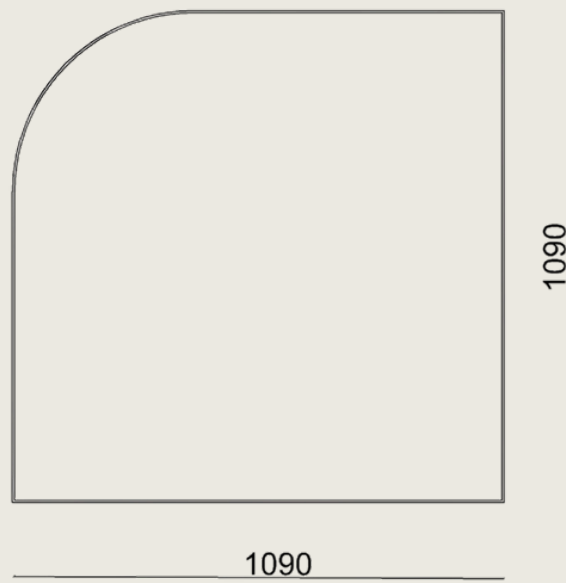

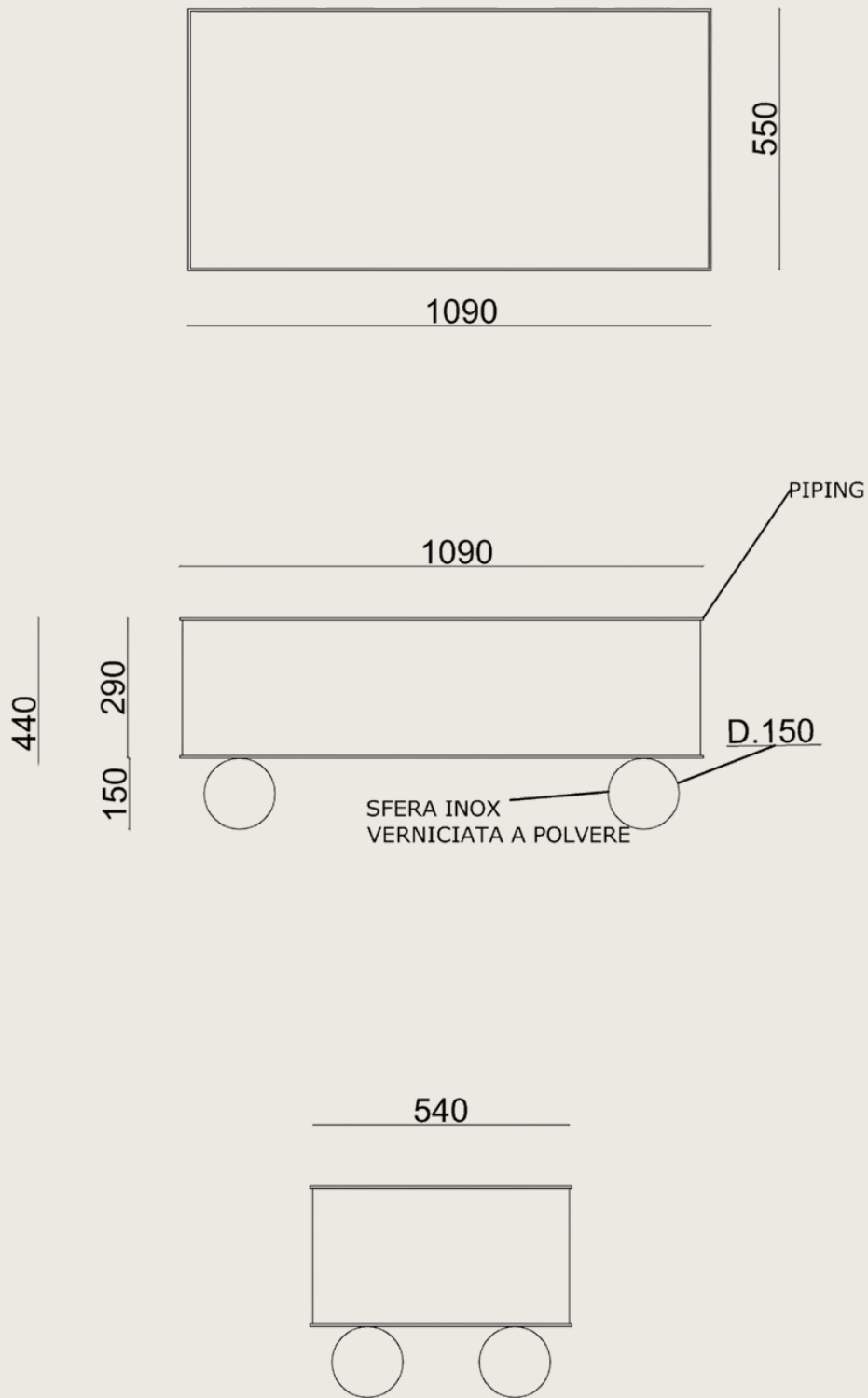

# Jimmy

/ Giuseppe Dicecca

## Stool



Fireproof



Indoor

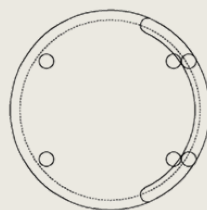
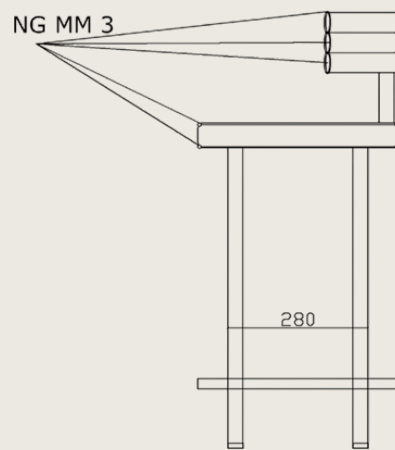
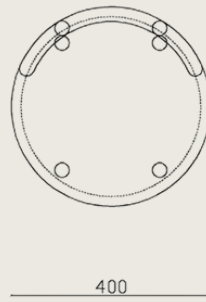
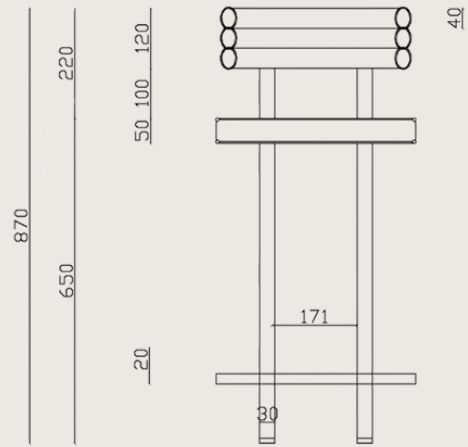

# Demont-Moi

/ Giuseppe Dicecca

Armchair



Easy removable



Outdoor



Indoor

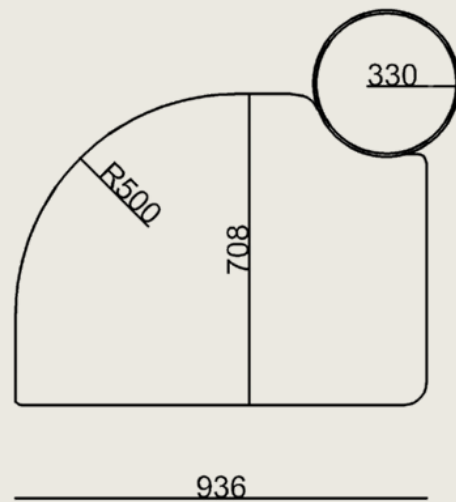
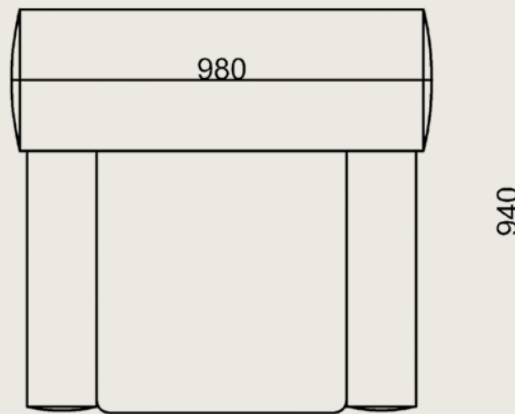
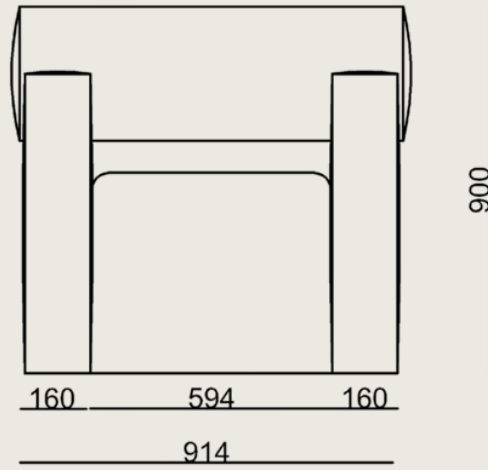



# Martingale

/ Giuseppe Dicecca

## Armchair



 Easy removable

 Outdoor

 Indoor

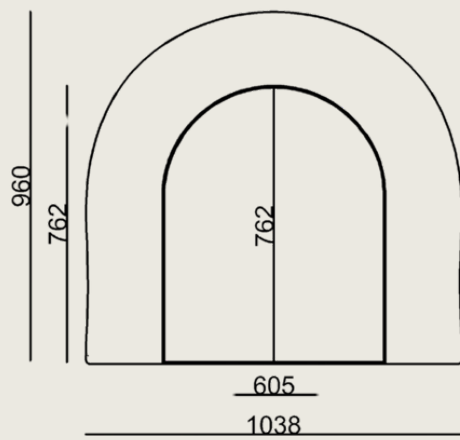
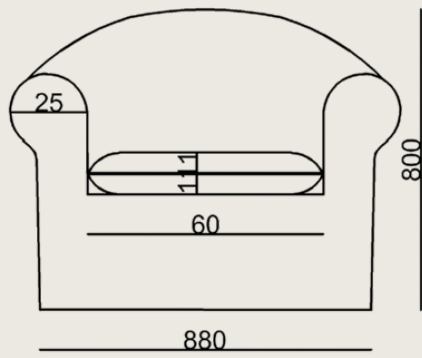
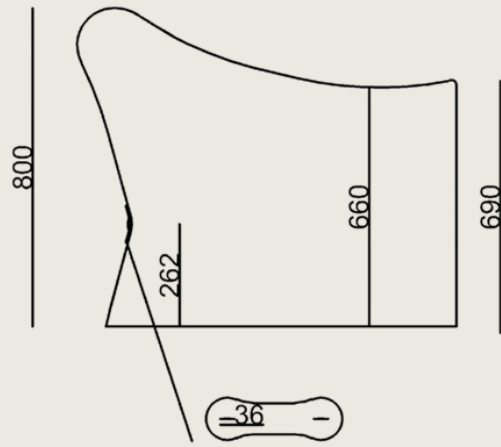

# PAOLONESI

**Paolo Nesi srl**

**Registered Office and Administrative  
Headquarters:**

**Località Drove, 1, 53036 Poggibonsi SI**

**T +39 0577 979587**

**Showroom:**

**Via Carlo de Angeli, 3, 20141 Milano**

**T +39 0243414660**

April, 2025 All rights are reserved.

No part of this publication may be reproduced, stored in a retrieval system  
or transmitted in any  
form or any means , electronic, mechanical,  
phocopying, recording or otherwise, without prior consent of the company.